

FIORI

DB 460 Stage III B

BETONIERA SEMOVENTE AUTOCARICANTE
SELF-PROPELLED SELF-LOADING
CONCRETE MIXER

BÉTONNIÈRE AUTOMOTRICE AUTOCHARGEUSE
SELBSTFAHRENDE UND SELBSTLADENDE
BETONMISCHMASCHINE

HORMIGONERA AUTOMOTOR AUTOCARGADORA
BETONEIRA AUTOPROPULSORA COM
AUTOCARREGAMENTO

- it_IT** CATALOGO PARTI DI RICAMBIO
- en_UK** SPARE PARTS CATALOGUE
- fr_FR** CATALOGUE PIÈCES DÉTACHÉES
- de_DE** ERSATZTEILKATALOG
- es_ES** CATALOGO PIEZAS DE REPUESTO
- pt_PT** CATÁLOGO DE PEÇAS DE REPOSIÇÃO

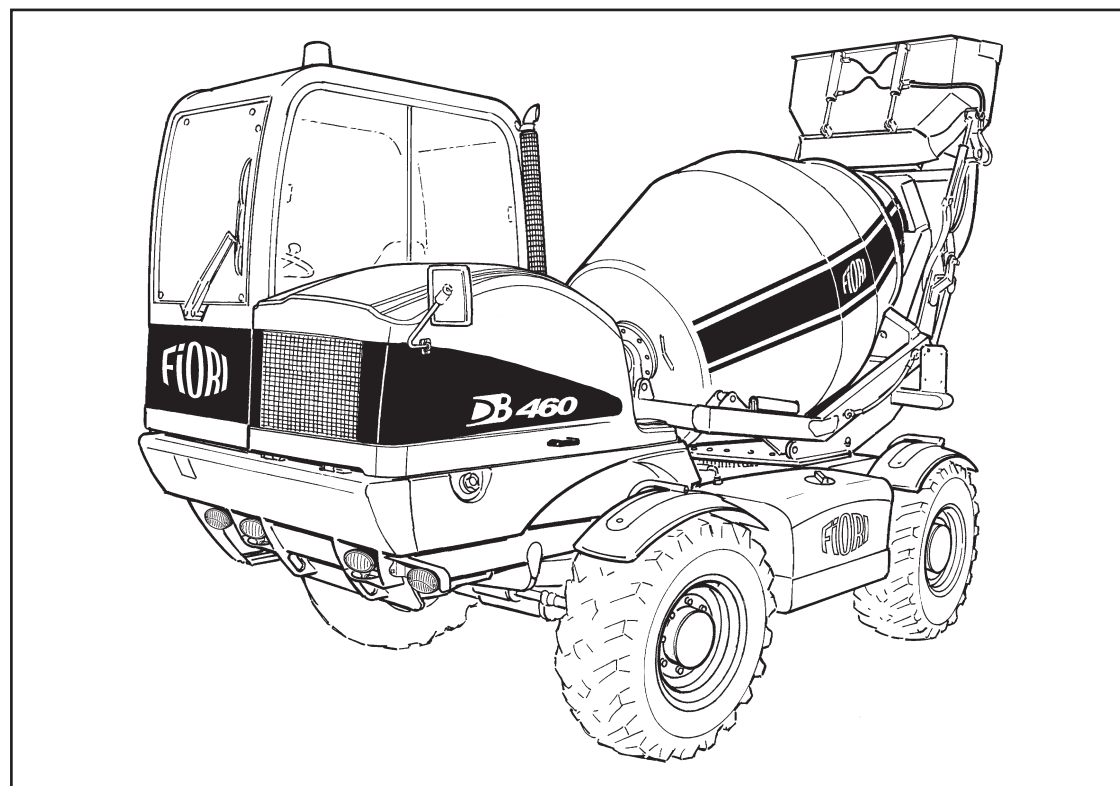















FIORI GROUP S.p.A.

Via per Ferrara, 7
41034 FINALE EMILIA (Modena Italia)
Tel.0535/92 35 7 - Telefax 0535/90 96 0
<http://www.fiorigroup.com>

RIF. 9302445006

Ed. 01 / Rev. 06

SIMBOLI

-  Indica più modelli, più versioni
-  Codifica con continuazione da pagina precedente
-  Codifica che continua in pagina successiva
-  Particolari non forniti separatamente
-  Particolare destro
-  Particolare sinistro
-  Codice di raggruppamento
-  Optional
-  Standard
-  Note generali
-  Note generali
-  Codici riportati in tabella
-  Codice di raggruppamento
-  Valida da matricola
-  Particolare composto da più pezzi montati

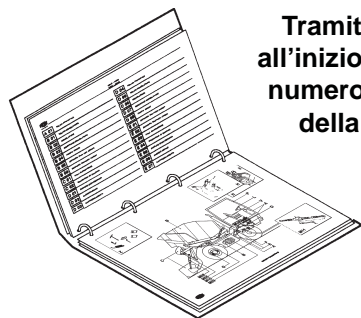

Tramite l'indice figurativo, posto all'inizio del catalogo, si individua il numero di tavola relativa alla parte della macchina che interessa.

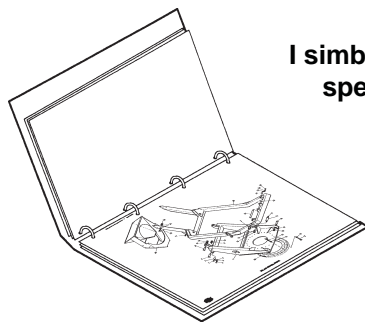

I simboli rappresentano alcune specifiche di costruzione.



FIORI GROUP S.p.A.
Finale Emilia (Modena) Italy

TYPE: _____ MACHINE: SELF LOADING MOBILE MIXER

SERIAL NUMBER: _____

OPERATING MASS: _____ kg

ENGINE POWER: _____



MANUFACTURE YEAR _____

315503

FIORI GROUP S.p.A. si riserva il diritto di modifiche

LA RIPRODUZIONE, LA DIVULGAZIONE E L'UTILIZZO PARZIALE O TOTALE DI QUESTO DOCUMENTO, CON QUALSIASI MEZZO, NON SONO CONSENTITE SENZA IL PREVENTIVO CONSENSO SCRITTO DELLA TITOLARE DEI DIRITTI. EVENTUALI INFRAZIONI SARANNO PERSEGUITE NEI MODI E NEI TEMPI PREVISTI DALLA LEGGE.

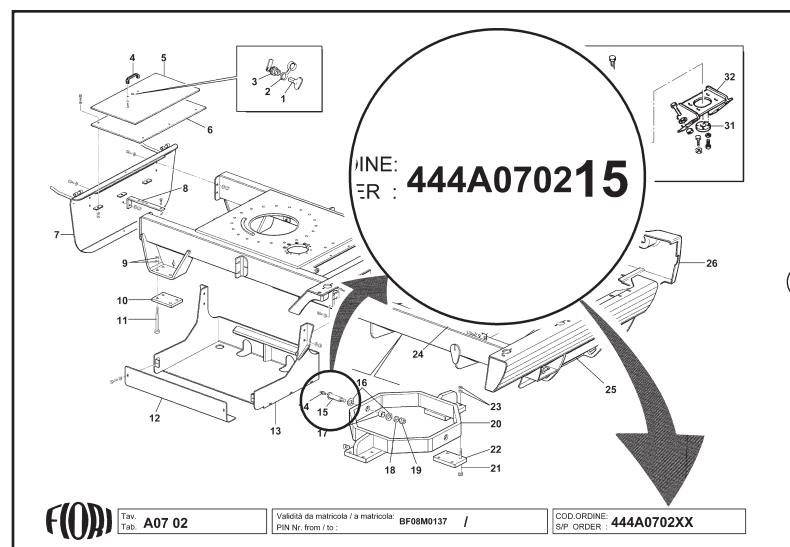



LE ORDINAZIONI DELLE PARTI DI RICAMBIO DEVONO ESSERE CORREDATE DALLE SEGUENTI INDICAZIONI:

- 1) Modello macchina (rif. A)
- 2) Matricola (rif. B)
- 3) Codice d'ordine (rif. C):
Comporre il vostro codice d'ordine sostituendo ad "XX" il numero di riferimento del particolare indicato sulla tavola

NOTA:
EFFETTUARE LA RICHIESTA DEI RICAMBI COMPILANDO L'APPOSITO ORDINE IN OGNI SUA PARTE

SYMBOLS

 Indicates more than one model and version

 Coding continued from previous page

 Coding continued on next page

 Parts not supplied separately

 Right-hand part

 Left-hand part

 Grouping code

 Optional

 Standard

 General notes



General notes

 Codes listed in the table

 Grouping code

 Valid from serial number

 Part made up of several assembled pieces

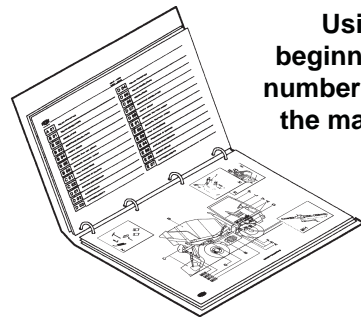

Using the figurative index at the beginning of the catalogue, identify the number of the table relating to the part of the machine you need a spare part for.

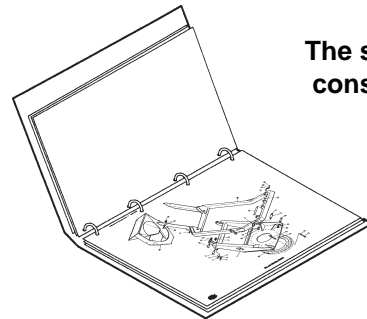

The symbols represent some construction specifications.

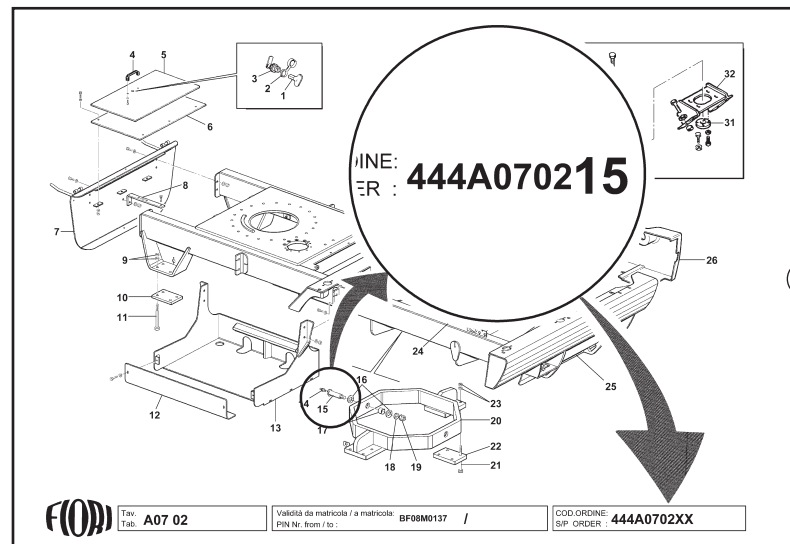

FIORI FIORI GROUP S.p.A.
Finale Emilia (Modena) Italy

TYPE: _____ MACHINE: SELF LOADING MOBILE MIXER

SERIAL NUMBER: _____

OPERATING MASS: _____ kg

ENGINE POWER: _____

 MANUFACTURE YEAR _____ 315503

A **B**

FIORI GROUP S.p.A. reserves the right to make any modifications it sees fit.

NO PART OF THIS DOCUMENT MAY BE REPRODUCED, STORED IN A RETRIEVAL SYSTEM OR TRANSMITTED IN ANY FORM OR BY ANY MEANS WITHOUT THE PRIOR WRITTEN PERMISSION OF THE COPYRIGHT OWNER.
ANY VIOLATIONS WILL BE PROSECUTED BY LAW.

WHEN ORDERING SPARE PARTS, INDICATE THE FOLLOWING :

1) Machine model (ref. A)

2) Serial number (ref. B)

3) Order code: (ref. C)

make up your order code by replacing "XX" with the part reference number indicated in the table.

NOTE:
ORDER THE SPARE PARTS BY FILLING IN THE ORDER FORM IN ALL OF ITS PARTS

SYMBOLES

 Indique plusieurs modèles, plusieurs versions

 Codage qui continue de la page précédente

 Codage qui continue à la page successive

 Pièces non fournies séparément

 Pièce droite

 Pièce gauche

 Code de regroupement

 Option

 Standard

 Notes générales



 Codes figurant dans le tableau

 Code de regroupement

 Valable à partir du numéro de série

 Pièce formée de plusieurs éléments démontés

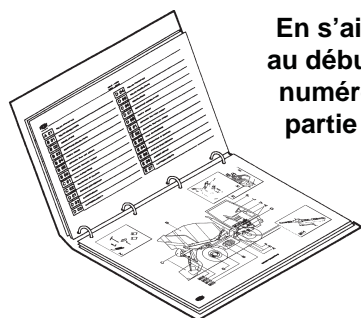

En s'aidant de l'index des figures au début du catalogue, identifier le numéro de la table concernant la partie de la machine concernée.

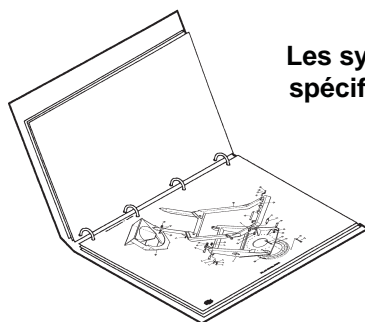

Les symboles représentent des spécifications de construction.

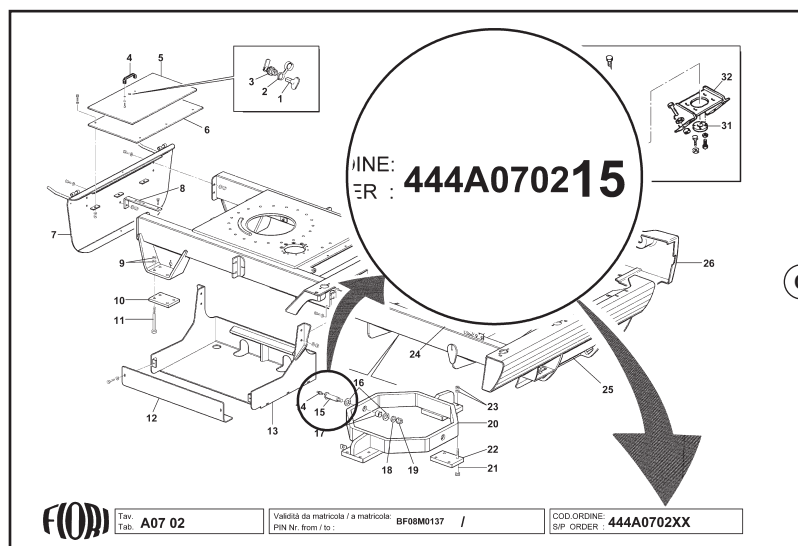

FIORI FIORI GROUP S.p.A.
Finale Emilia (Modena) Italy

TYPE: _____ MACHINE: SELF LOADING MOBILE MIXER

SERIAL NUMBER: _____

OPERATING MASS: _____ kg

ENGINE POWER: _____

 MANUFACTURE YEAR _____

315503

A

B

FIORI GROUP S.p.A. se réserve le droit d'apporter des modifications

LA RÉPRODUCTION, LA DIFFUSION ET L'UTILISATION PARTIELLE OU TOTALE DE CE DOCUMENT, PAR QUELQUE MOYEN QUE CE SOIT, NE SONT PAS AUTORISÉES SANS LA PRÉALABLE AUTORISATION ÉCRITE DU TITULAIRE DES DROITS. LES INFRACTIONS ÉVENTUELLES SERONT POURSUIVIES SUIVANT LES MODÈS ET DANS LES DÉLAIS PRÉVUS PAR LA LOI.

LES COMMANDES DES PIÈCES DÉTACHÉES DOIVENT ÊTRE ACCOMPAGNÉES DES INDICATIONS SUIVANTES:

1) Modèle machine (réf. A)

2) Numéro de série (réf. B)

3) Code de commande (réf. C):

Composez votre code de commande en remplaçant "XX" par le numéro de référence de la pièce indiqué sur la table

NOTE :
EFFECTUER LA DEMANDE DES PIÈCES EN REMPLISSANT LE FORMULAIRE PRÉVU A CET EFFET DANS TOUTES SES PARTIES



SYMBOLE

 Mehrere Modelle, mehrere Versionen

 Von der vorherigen Seite fortgesetzte Nummerierung

 Nummerierung wird auf der nächsten Seite fortgesetzt

 Nicht separat lieferbare Teile

 Rechtes Teil

 Linkes Teil

 Gruppencode

 Optional

 Standard

 Allgemeine Anmerkungen



 In der Tabelle aufgeführte Artikelnummern

 Gruppencode

 Gültig ab Serien-Nummer

 Bauteil bestehend aus mehreren montierten Teilen

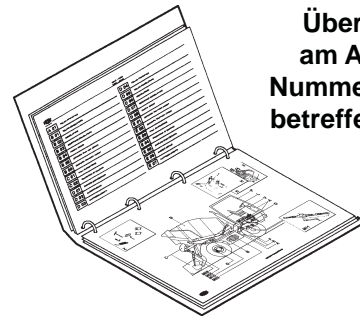

Über das Abbildungsverzeichnis am Anfang des Katalogs wird die Nummer der Abbildung bezüglich des betreffenden Maschinenteils gesucht.

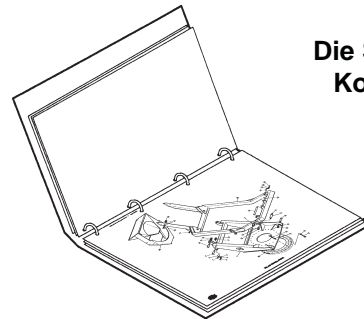

Die Symbole repräsentieren Konstruktionsmerkmale.

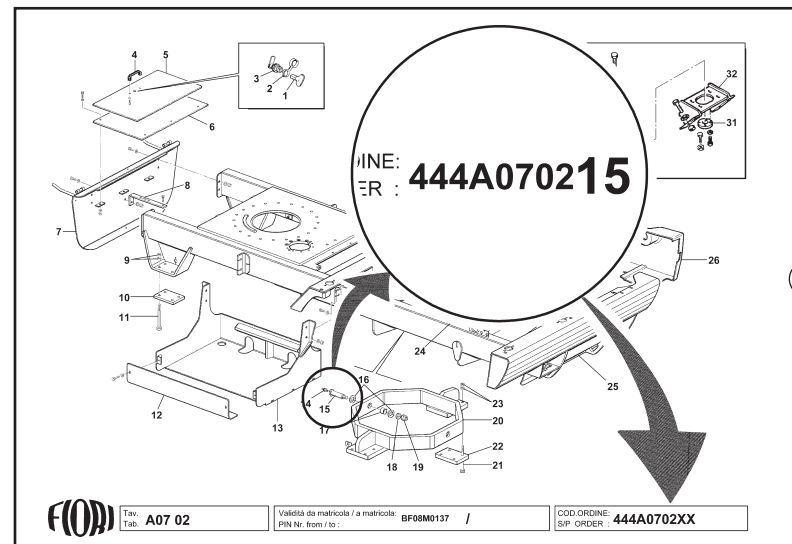

FIORI FIORI GROUP S.p.A.
Finale Emilia (Modena) Italy

TYPE: _____ MACHINE: SELF LOADING MOBILE MIXER

SERIAL NUMBER: _____

OPERATING MASS: _____ kg

ENGINE POWER: _____

 MANUFACTURE YEAR _____

315503

FIORI GROUP S.p.A. Änderungen vorbehalten

DIE VERVIELFÄLTIGUNG, DIE WEITERVERBREITUNG UND DIE TEILWEISE ODER VOLLSTÄNDIGE VERWENDUNG DIESES DOKUMENTS MIT JEGLICHEM MITTEL SIND OHNE VORHERIGE SCHRIFTLICHE GENEHMIGUNG DES RECHTSINHABERS NICHT GESTATTET. ETWAIGE ZUWIDERHANDLUNGEN WERDEN GESETZLICH GEAHNDET.

DIE ERSATZTEILBESTELLUNGEN MÜSSEN DIE FOLGENDEN ANGABEN ENTHALTEN:

1) Maschinenmodell (Pos. A)















2) Serien-Nummer (Pos. B)

3) Bestellnummer (Pos. C):

Setzen Sie Ihre Bestellnummer zusammen, indem sie "XX" mit der Referenznummer des Teils auf der Abbildung ersetzen

ANMERKUNG:
FÜR DIE ERSATZTEILBESTELLUNG IST
DAS BESTELLFORMULAR VOLLSTÄNDIG AUSZUFÜLLEN

SÍMBOLOS

-  Indica varios modelos, varias versiones
-  Codificación con continuación desde la página precedente
-  Codificación que continua en la página sucesiva
-  Piezas no suministradas separadamente
-  Pieza derecha
-  Pieza izquierda
-  Código de agrupamiento
-  Opcional
-  Estándar
-  Notas generales
-  Notas generales
-  Códigos señalados en la tabla
-  Código de agrupamiento
-  Validación por matrícula
-  Pieza compuesta por varias piezas montadas

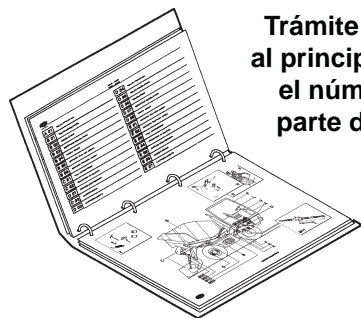

Trámite el índice figurativo, situado al principio del catálogo, se individúa el número de la tabla relativa y la parte de la máquina que interesa.

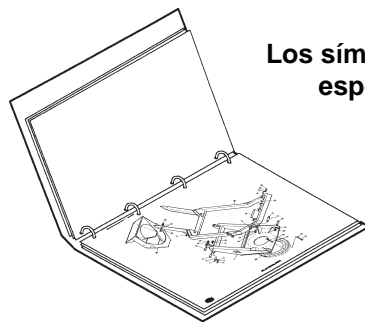

Los símbolos representan algunas especificaciones técnicas.

FIORI FIORI GROUP S.p.A.
Finale Emilia (Modena) Italy

TYPE: _____ MACHINE: SELF LOADING MOBILE MIXER

SERIAL NUMBER: _____

OPERATING MASS: _____ kg

ENGINE POWER: _____

 MANUFACTURE YEAR _____

315503

FIORI GROUP S.p.A. se reserva el derecho de realizar modificaciones

LA REPRODUCCIÓN, LA DIVULGACIÓN Y EL USO TOTAL O PARCIAL DE ESTE DOCUMENTO, CON CUALQUIER MEDIO, NO ESTÁN PERMITIDOS SIN EL PERMISO ESCRITO DEL TITULAR DE LOS DERECHOS. EVENTUALES INFRACCIONES SE PERSEGUIRÁN EN LOS MODOS Y EN LOS TIEMPOS PREVISTOS POR LA LEY.

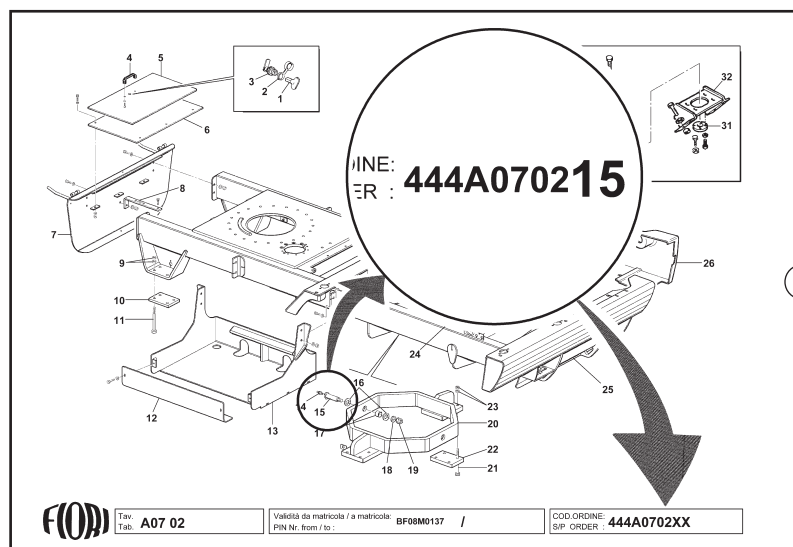















LOS PEDIDOS DE LAS PIEZAS DE REPUESTO DEBEN INCLUIR LAS SIGUIENTES INDICACIONES:

- 1) Modelo máquina (ref.A)
- 2) Matrícula (ref. B)
- 3) Código del pedido (ref. C):
Componer el código de pedido sustituyendo "XX" con el número de referencia de la pieza indicada en la tabla

NOTA:
EFECTUAR LA SOLICITUD DE LOS REPUESTOS RELLENANDO POR COMPLETO EL PEDIDO



SÍMBOLOS

-  Indica vários modelos, várias versões
-  Codificação com continuação a partir da página anterior
-  Codificação com continuação na página seguinte
-  Peças não fornecidas separadamente
-  Peça direita
-  Peça esquerda
-  Código de agrupamento
-  Opcional
-  De série
-  Observações gerais
-  Observações gerais
-  Códigos indicados em tabela
-  Código de agrupamento
-  Válida a partir do nº de série
-  Peça composta por mais peças montadas

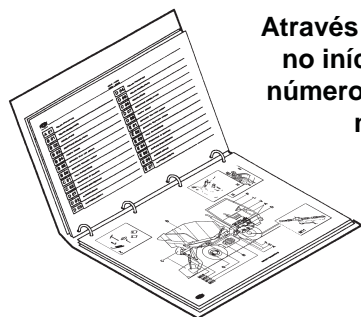

Através do índice de figuras, presente no início do catálogo, localiza-se o número do quadro relativo à parte da máquina que interessa.

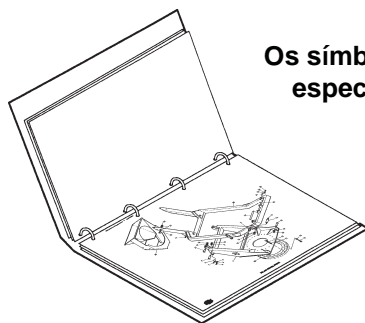

Os símbolos representam algumas especificações de construção.

FIORI FIORI GROUP S.p.A. Finale Emilia (Modena) Italy	
TYPE:	MACHINE: SELF LOADING MOBILE MIXER
SERIAL NUMBER:	
OPERATING MASS:	— kg
ENGINE POWER:	
	MANUFACTURE YEAR 315503

A FIORI GROUP S.p.A. reserva-se o direito de efetuar modificações

A REPRODUÇÃO, DIVULGAÇÃO E UTILIZAÇÃO PARCIAL OU TOTAL DESTA DOCUMENTO, COM QUALQUER SISTEMA, NÃO SÃO PERMITIDAS SEM A AUTORIZAÇÃO PRÉVIA POR ESCRITO DO TITULAR DOS DIREITOS. EVENTUAIS INFRAÇÕES SERÃO PERSEGUIDAS NOS MODOS E TEMPOS PREVISTOS PELA LEI.

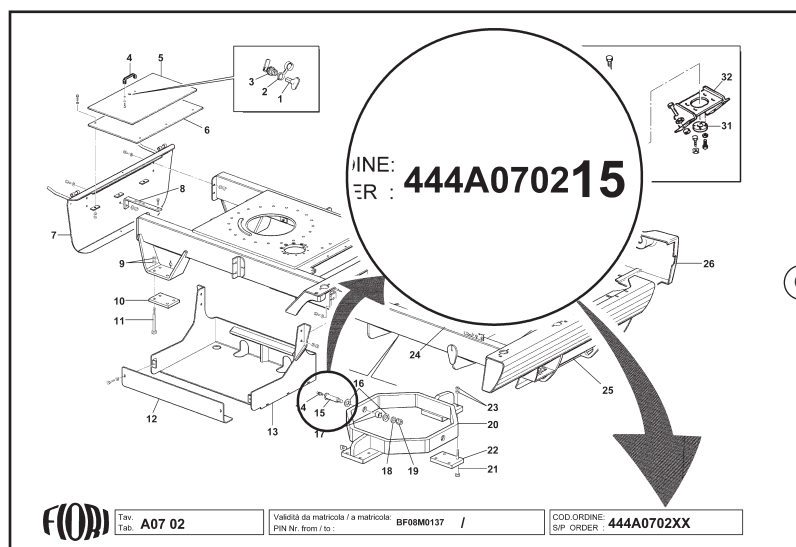

AS ENCOMENDAS DAS PEÇAS DE REPOSIÇÃO DEVEM SER ACOMPANHADAS DAS SEGUINTE INDICAÇÕES:

- 1) Modelo da máquina (ref.A)
- 2) Nº de série (ref. B)
- 3) Código de pedido (ref. C):
Componha o seu código de pedido substituindo os caracteres "XX" pelo número de referência da peça indicado no quadro

NOTA:
FAÇA O PEDIDO DAS PEÇAS PREENCHENDO O FORMULÁRIO DE PEDIDO EM TODAS AS SUAS PARTES



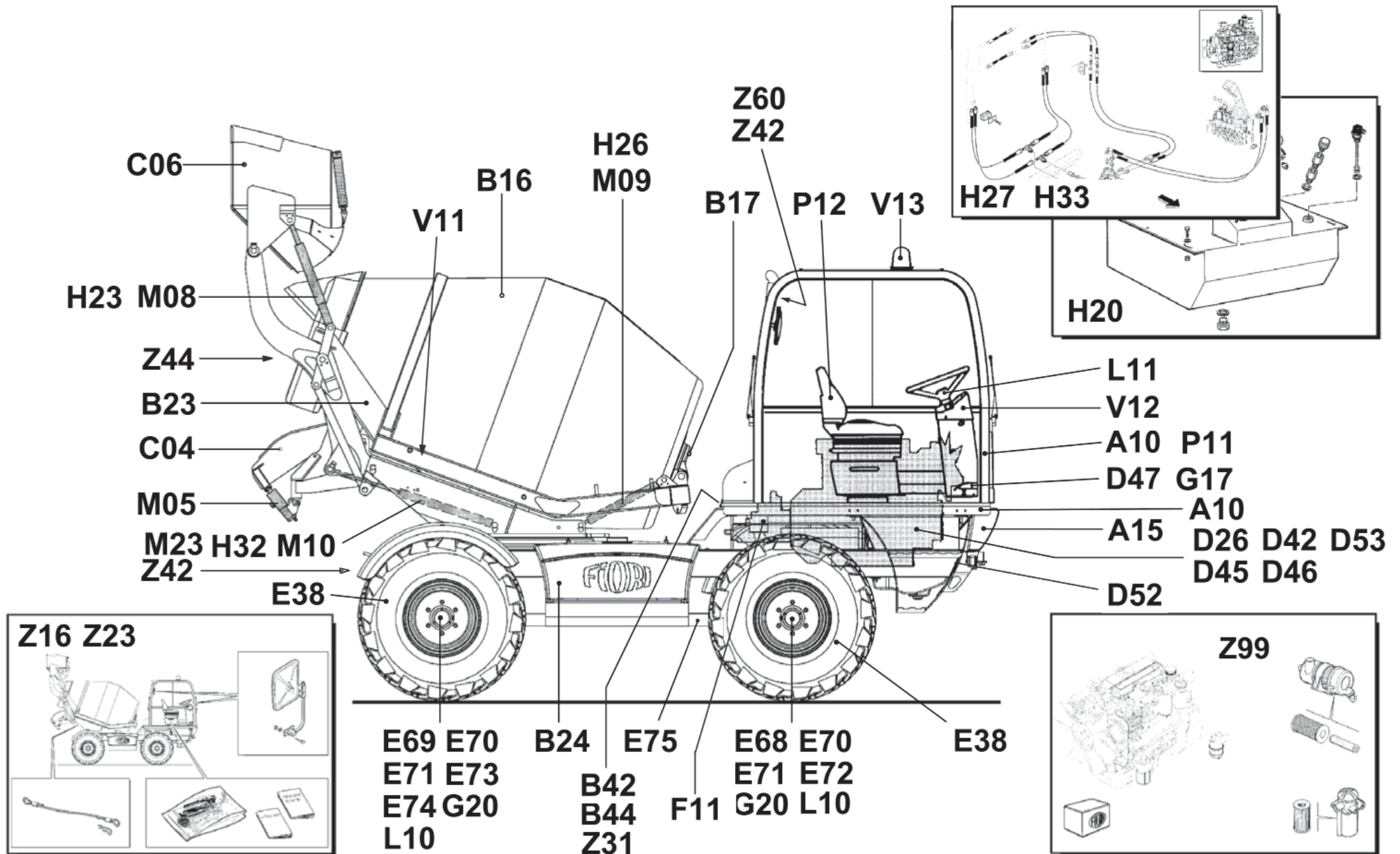

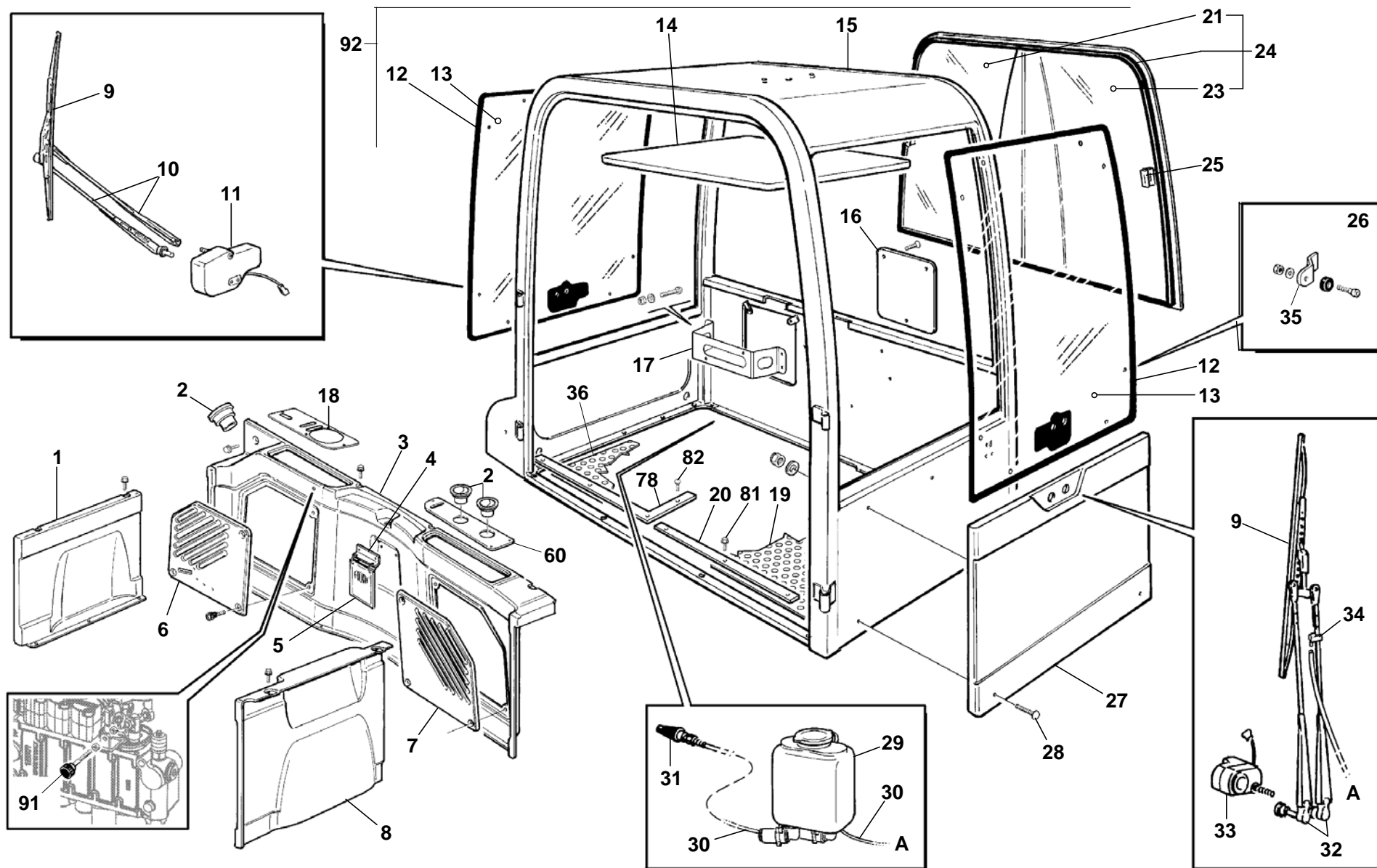

Tav. **A10 07 (1 of 2)**
 Tab.

Validità da matricola / a matricola: **BF08HB1354 /**
 PIN Nr. from / to :

COD.ORDINE: **445A1007XX**
 S/P ORDER :

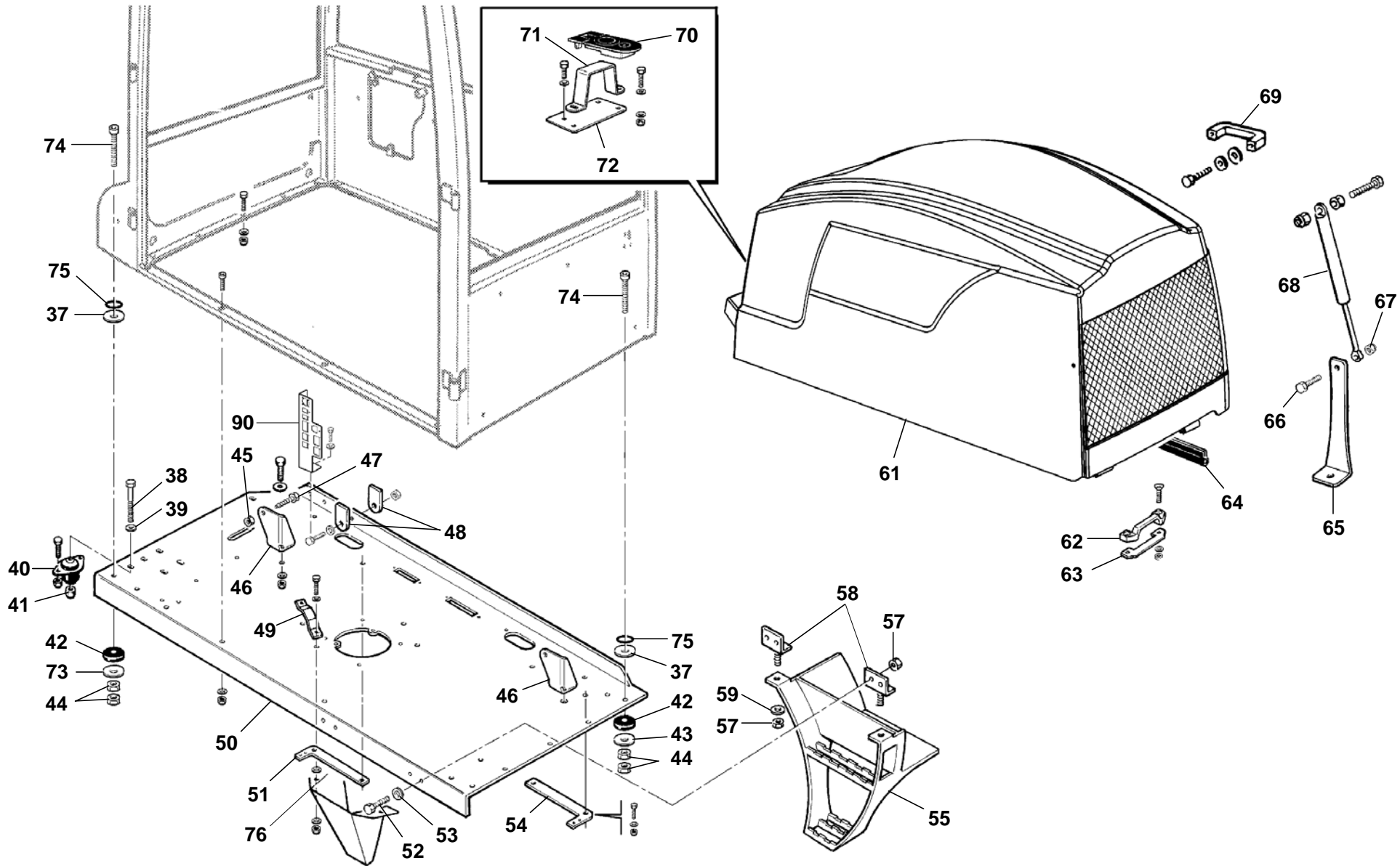

Tav. **A10 04 (2 of 2)**
 Tab.

Validità da matricola / a matricola: **BF08HB1078** /
 PIN Nr. from / to :

COD.ORDINE: **445A1004XX**
 S/P ORDER :

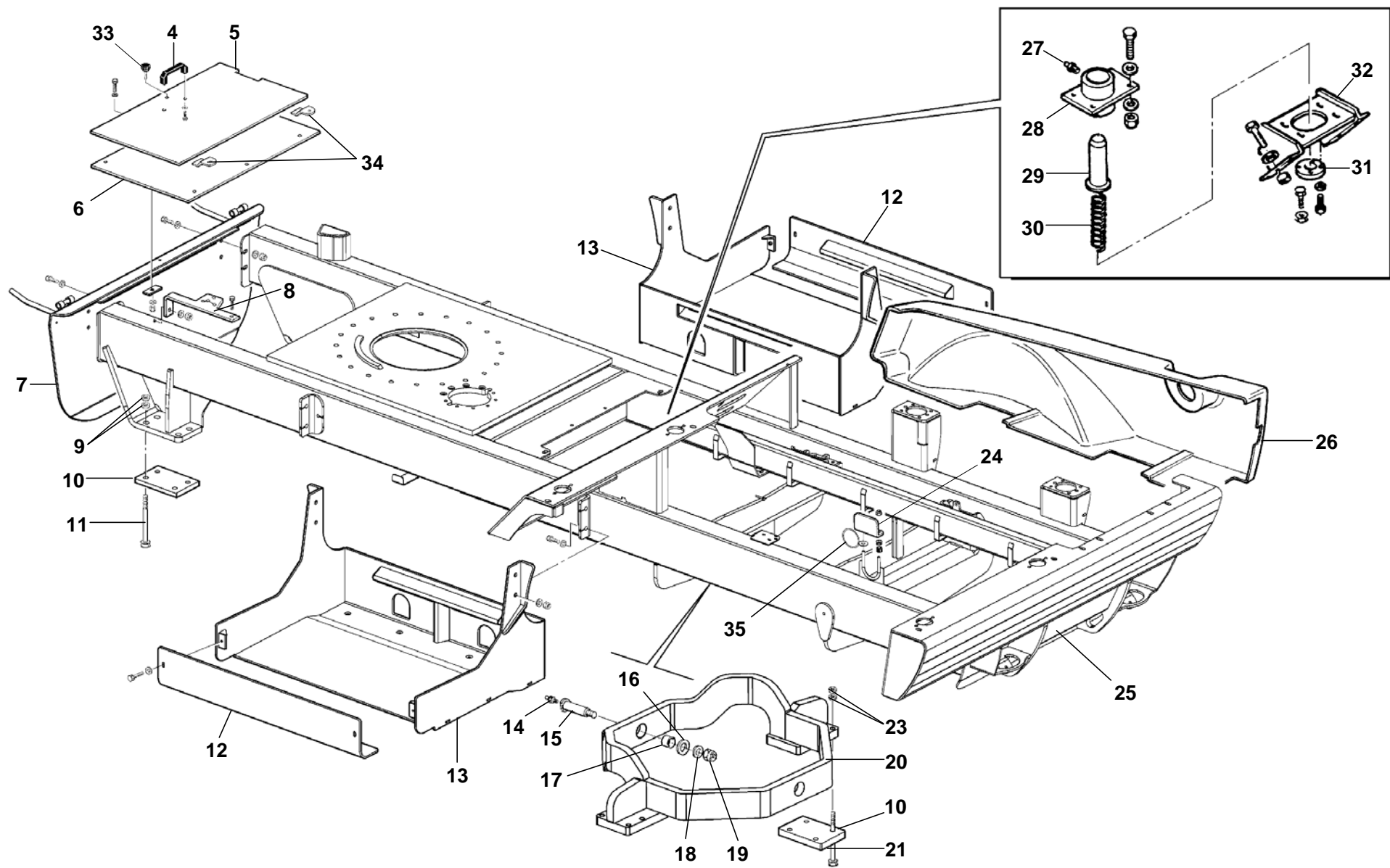

Tav. **A15 05**
 Tab.

Validità da matricola / a matricola: **BF08HB1078** /
 PIN Nr. from / to :

COD.ORDINE: **445A1505XX**
 S/P ORDER :

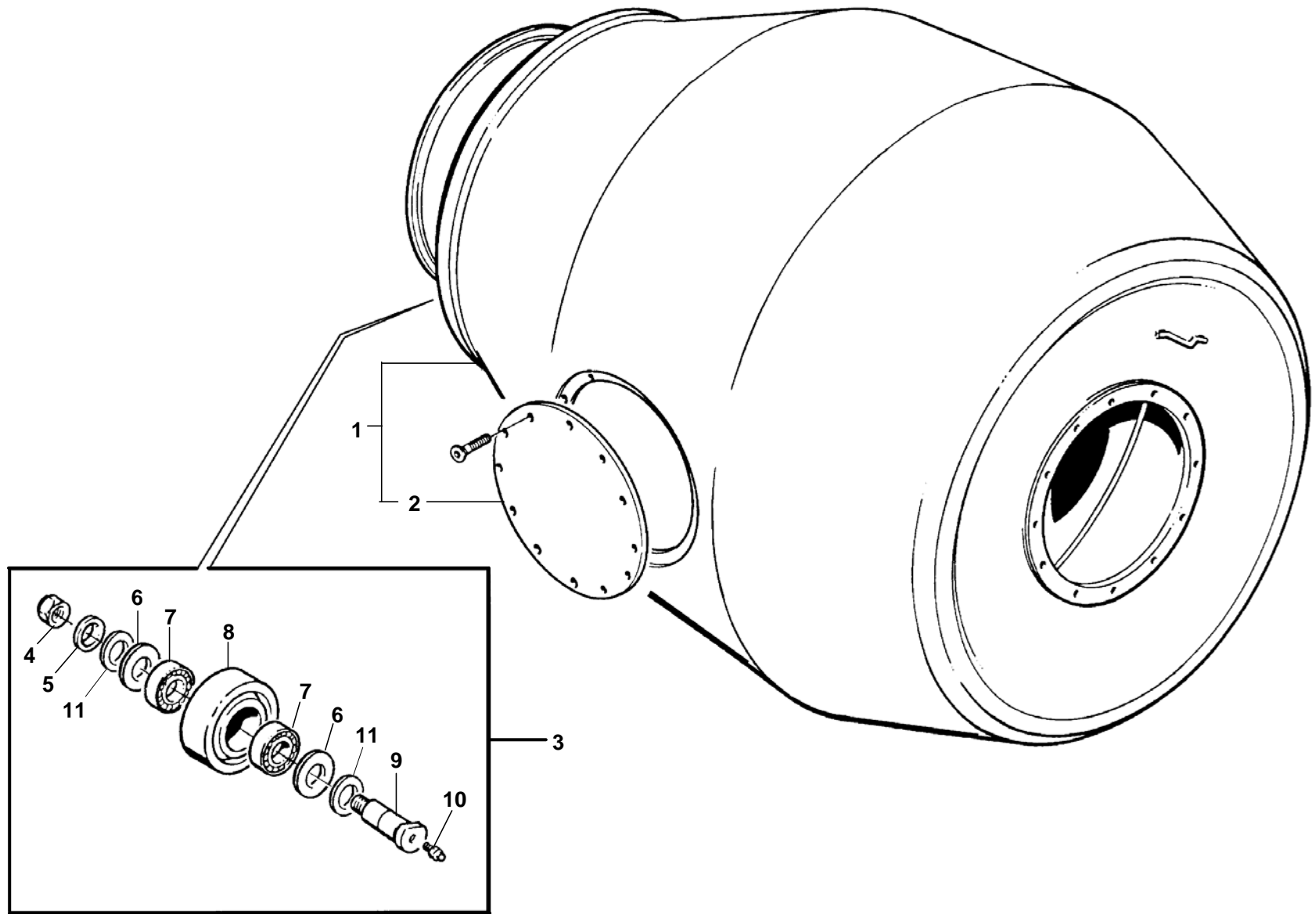

Tav. **B16 02**
 Tab.

Validità da matricola / a matricola: **BF08HB1078** /
 PIN Nr. from / to :

COD.ORDINE: **445B1602XX**
 S/P ORDER :

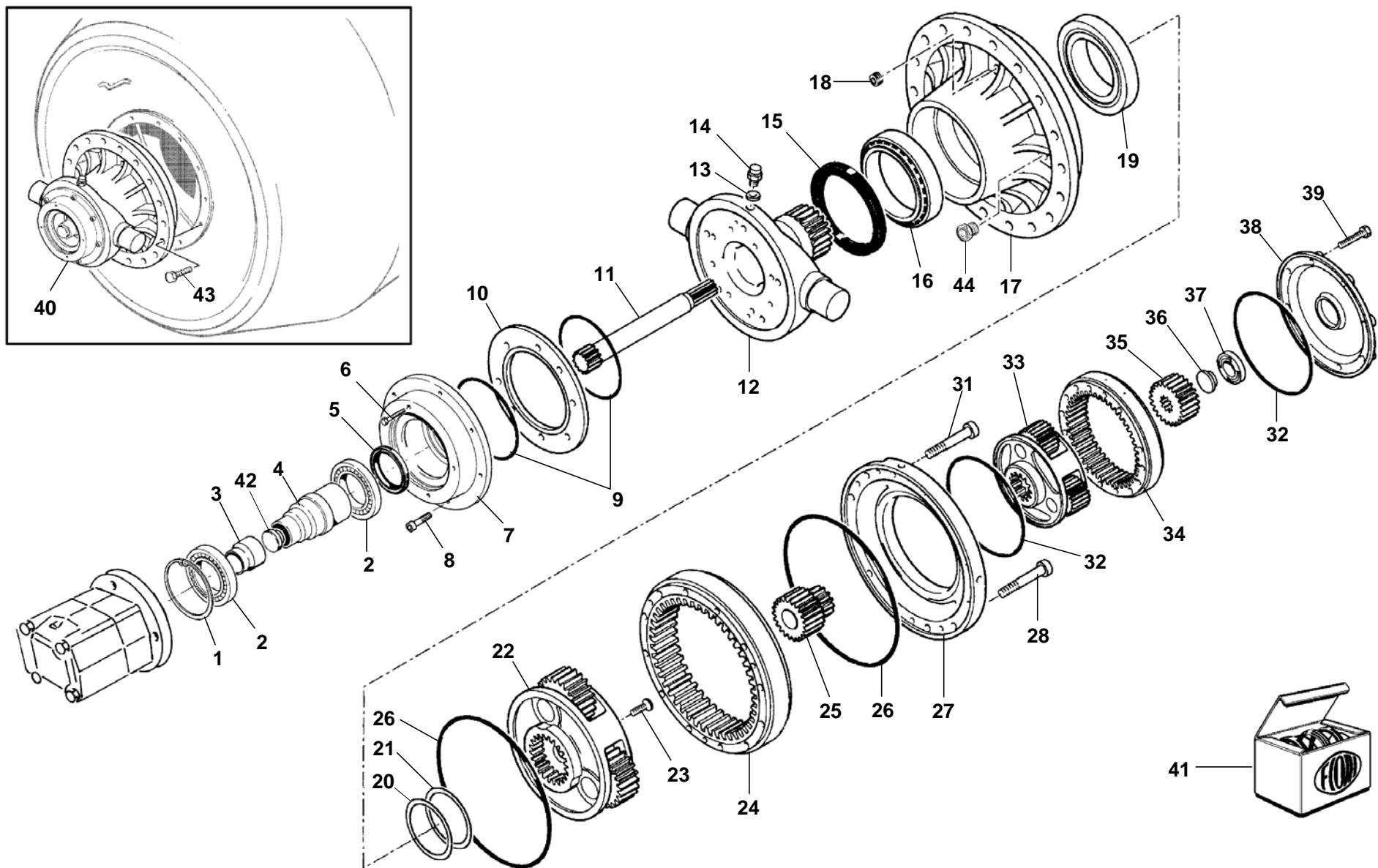

Tav. **B17 03**
 Tab.

Validità da matricola / a matricola: **BF08HB1111** /
 PIN Nr. from / to :

COD.ORDINE: **445B1703XX**
 S/P ORDER :

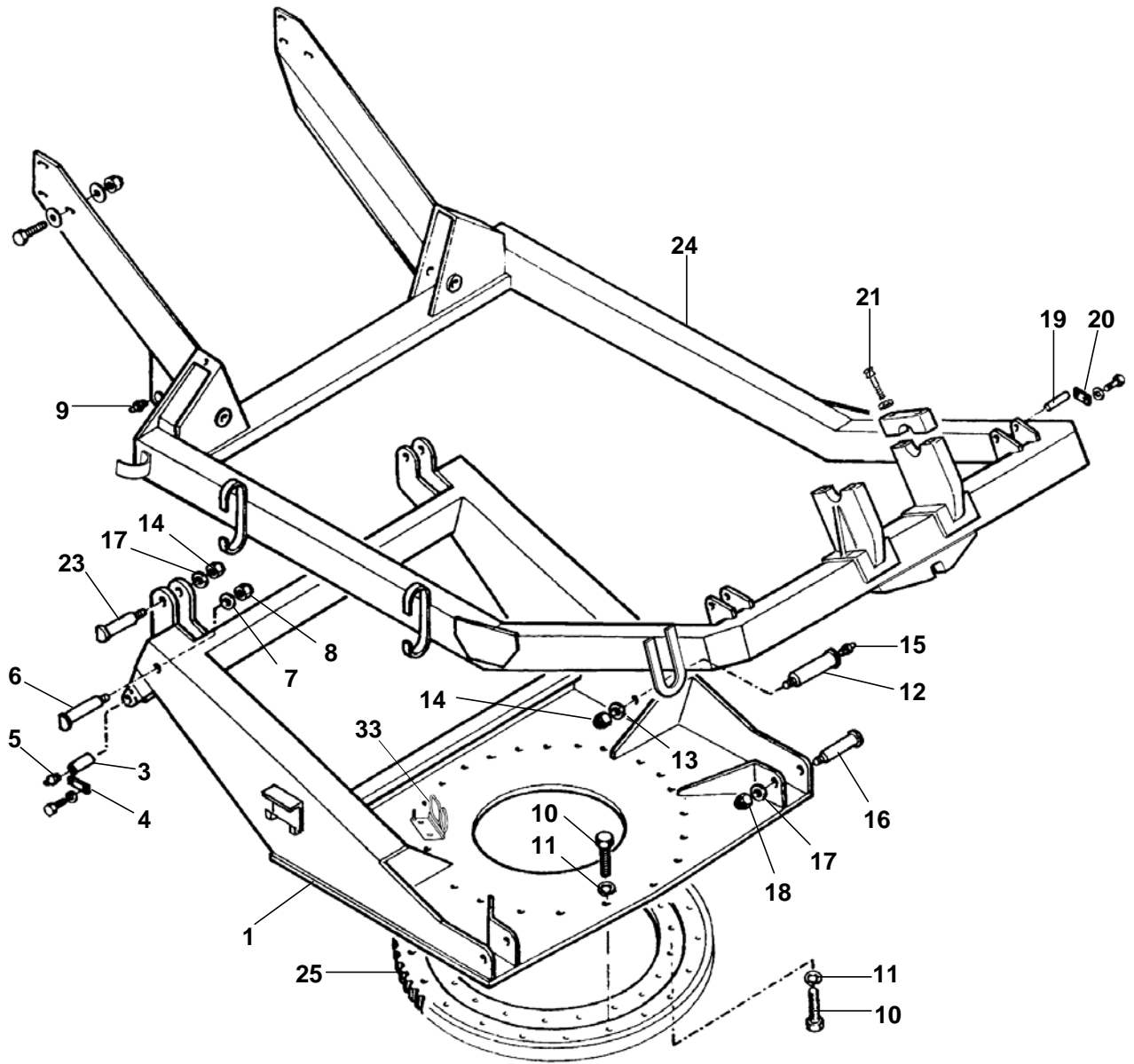
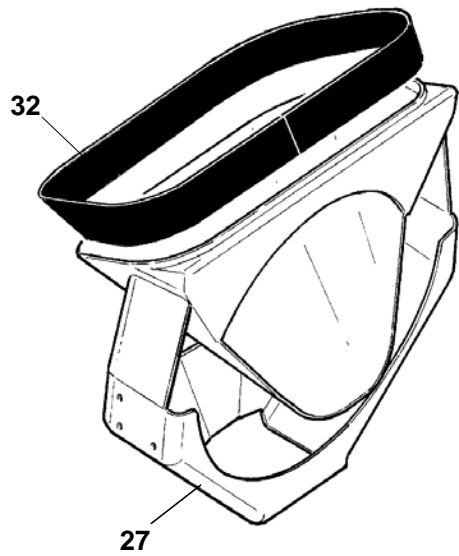

Tav. **B23 04**
Tab.

Validità da matricola / a matricola: **BF08HB1078** /
PIN Nr. from / to :

COD.ORDINE: **445B2304XX**
S/P ORDER :

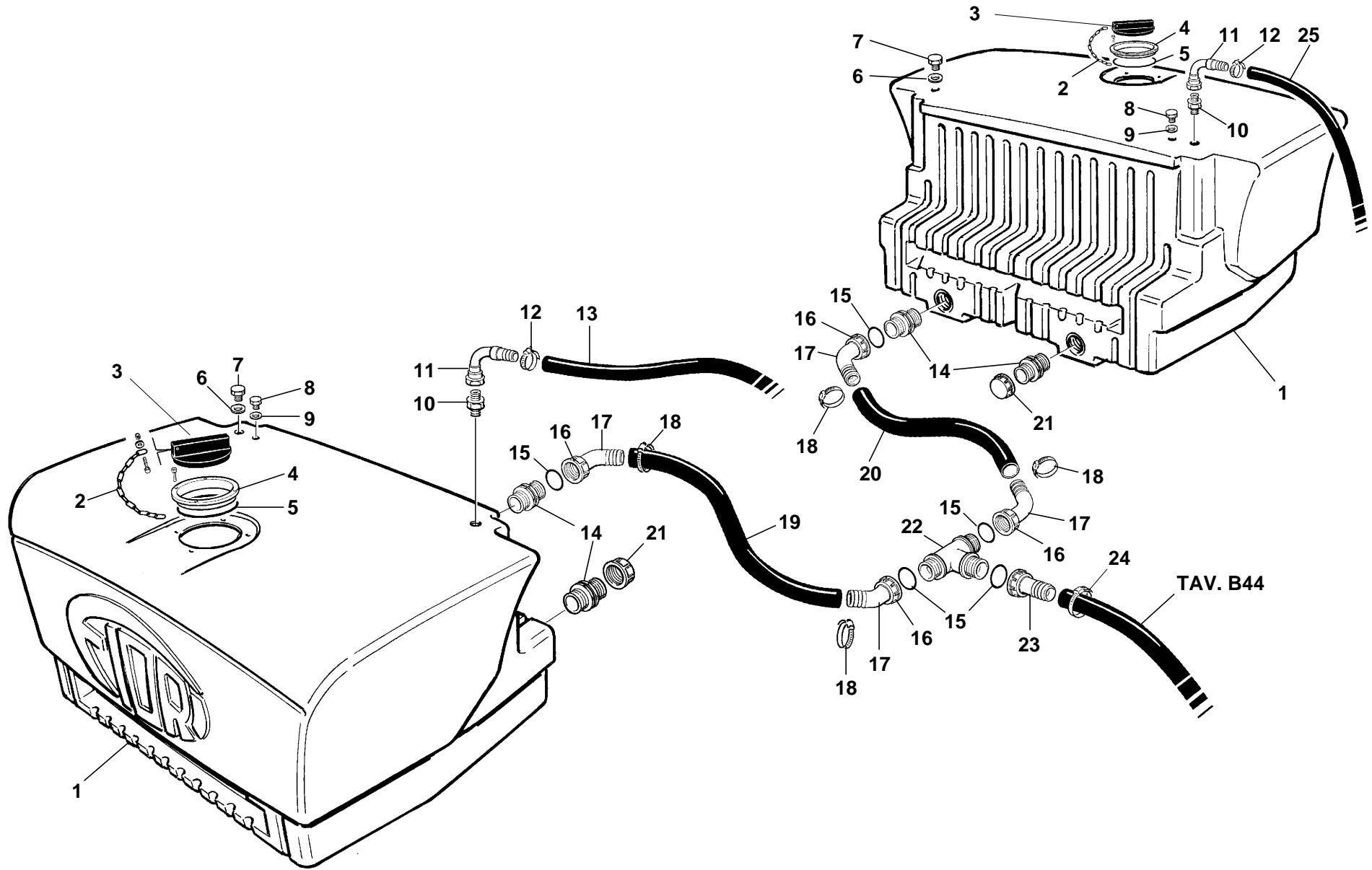

Tav. **B24 03**
Tab.

Validità da matricola / a matricola: **BF08HB1078** /
PIN Nr. from / to :

COD.ORDINE: **445B2403XX**
S/P ORDER :

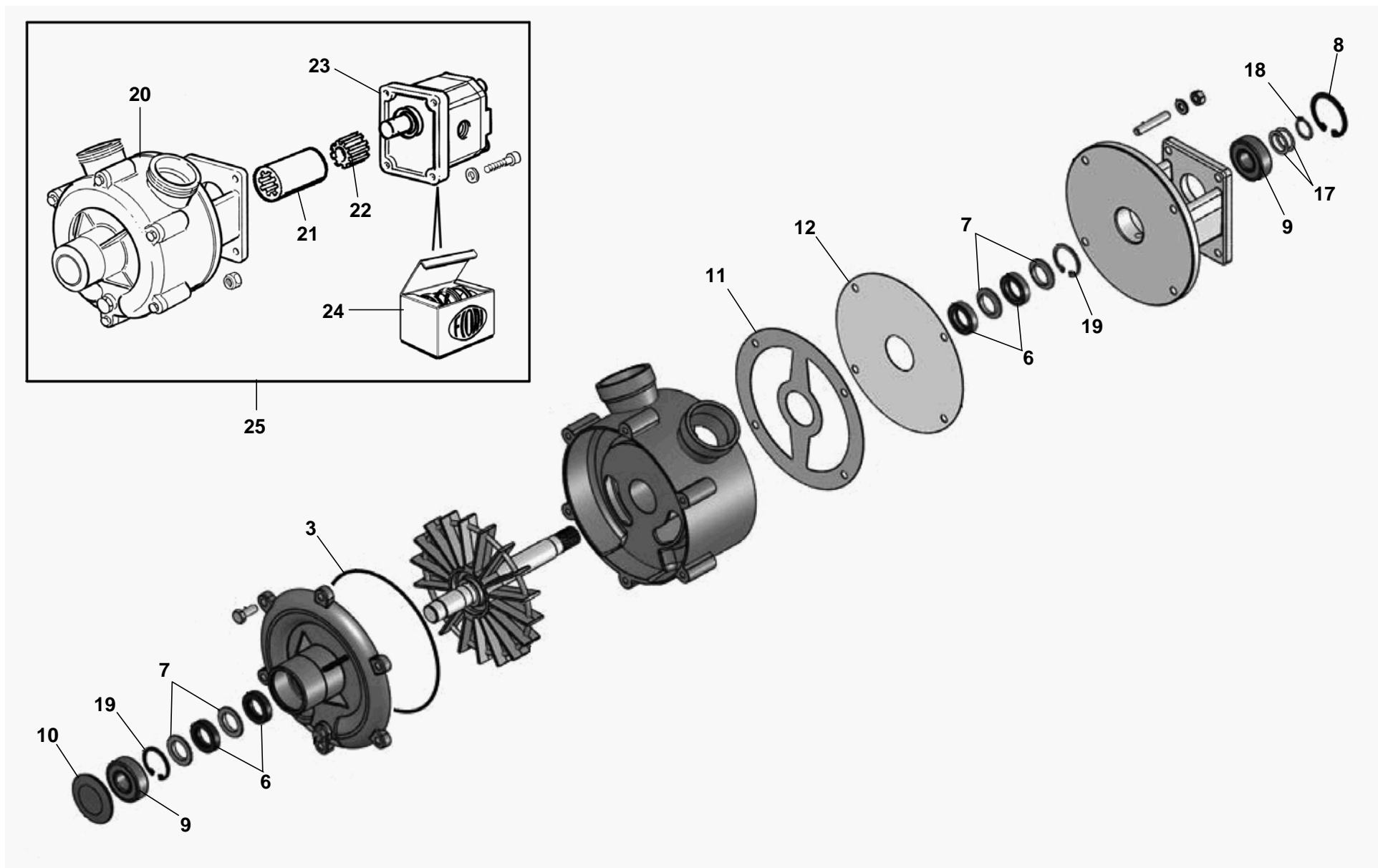

Tav. **B42 01**
Tab.

Validità da matricola / a matricola: **BF08HB1078** /
PIN Nr. from / to :

COD.ORDINE: **445B4201XX**
S/P ORDER :

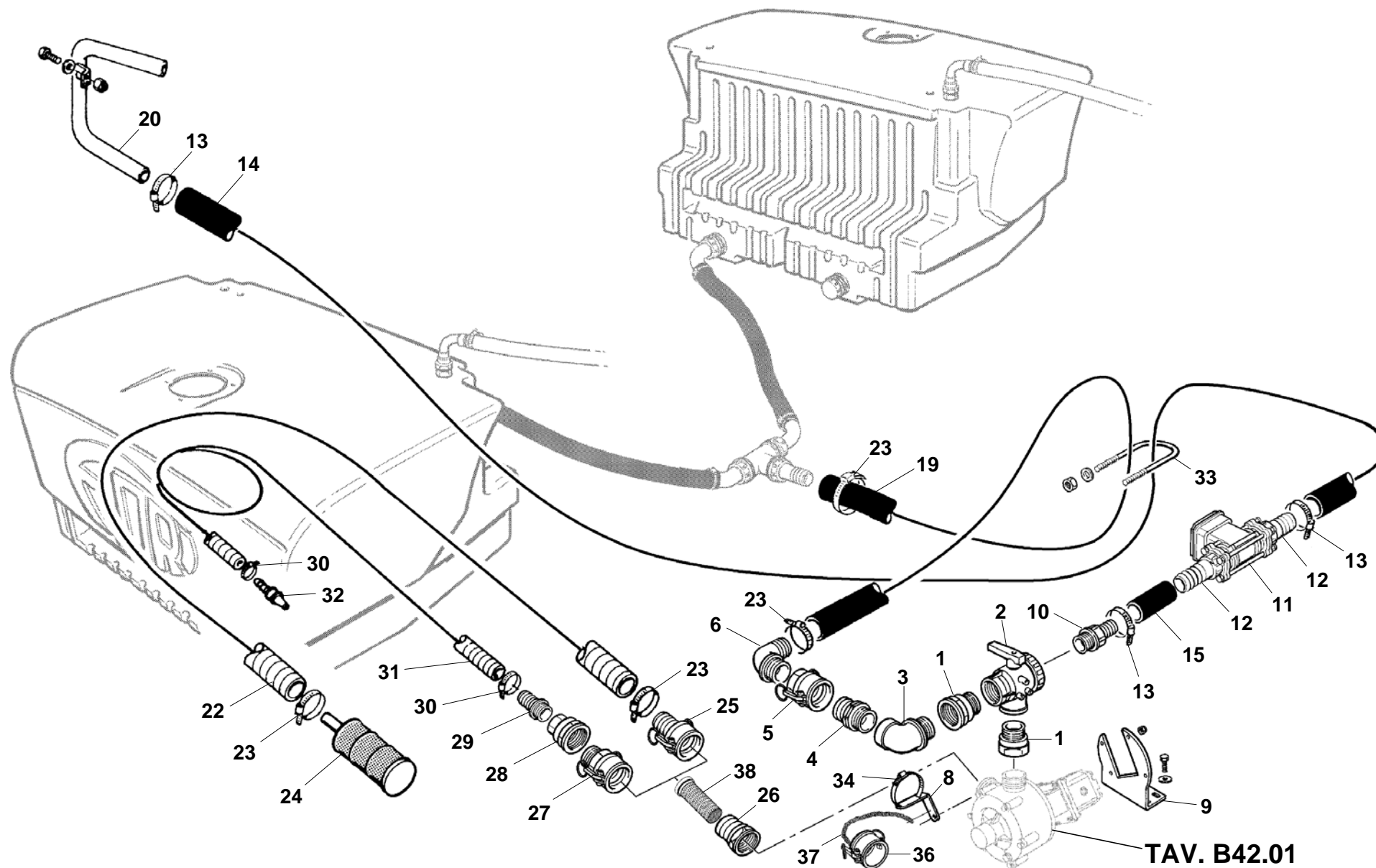

Tav. **B44 03**
Tab.

Validità da matricola / a matricola: **BF08HB1078** /
PIN Nr. from / to :

COD.ORDINE: **445B4403XX**
S/P ORDER :

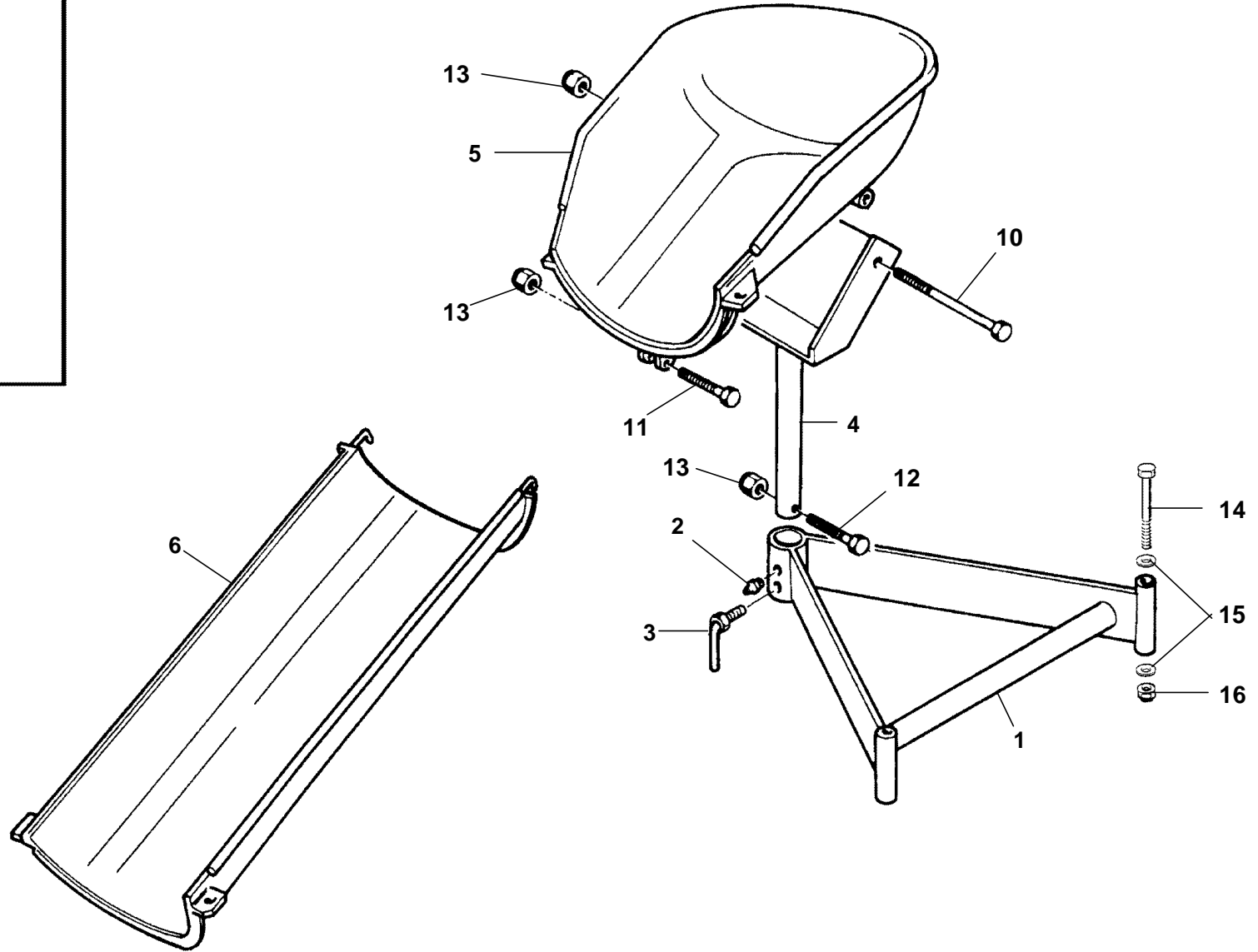
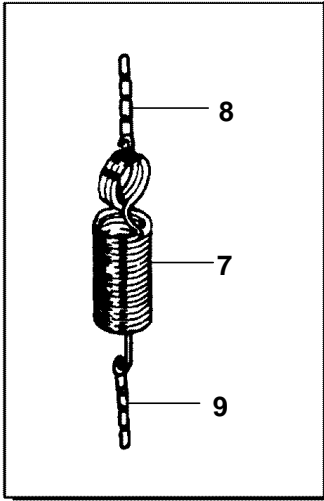

Tav. **C04 02**
 Tab.

Validità da matricola / a matricola: **BF08HB1078** /
 PIN Nr. from / to :

COD.ORDINE: **445C0402XX**
 S/P ORDER :

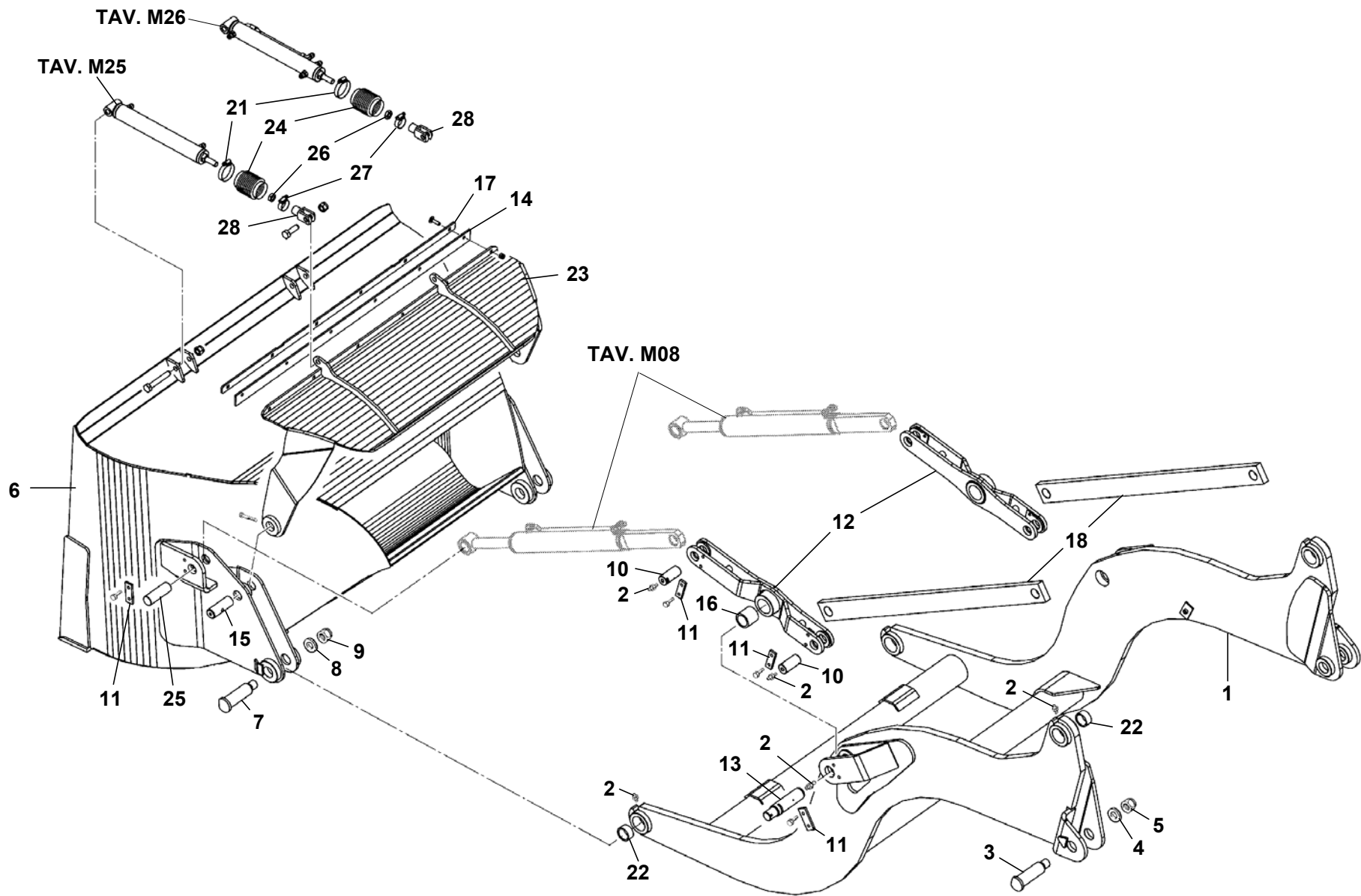

Tav.
 Tab. **C06 04**

Validità da matricola / a matricola:
 PIN Nr. from / to : **BF08HB1525 /**

COD.ORDINE:
 S/P ORDER : **445C0604XX**

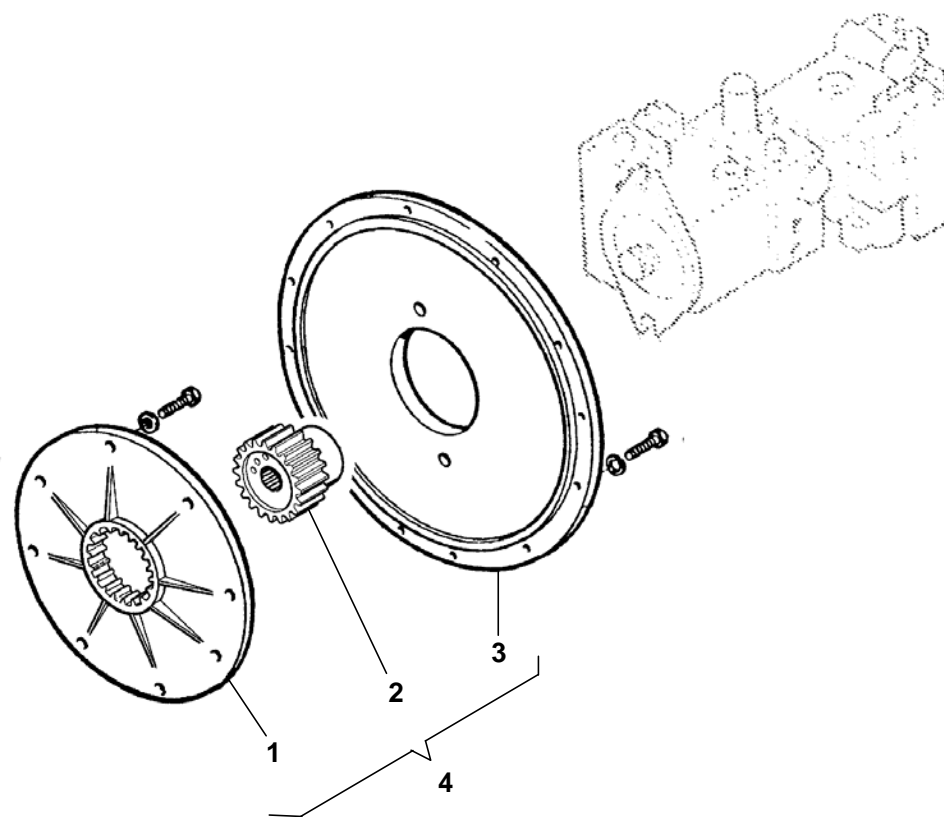
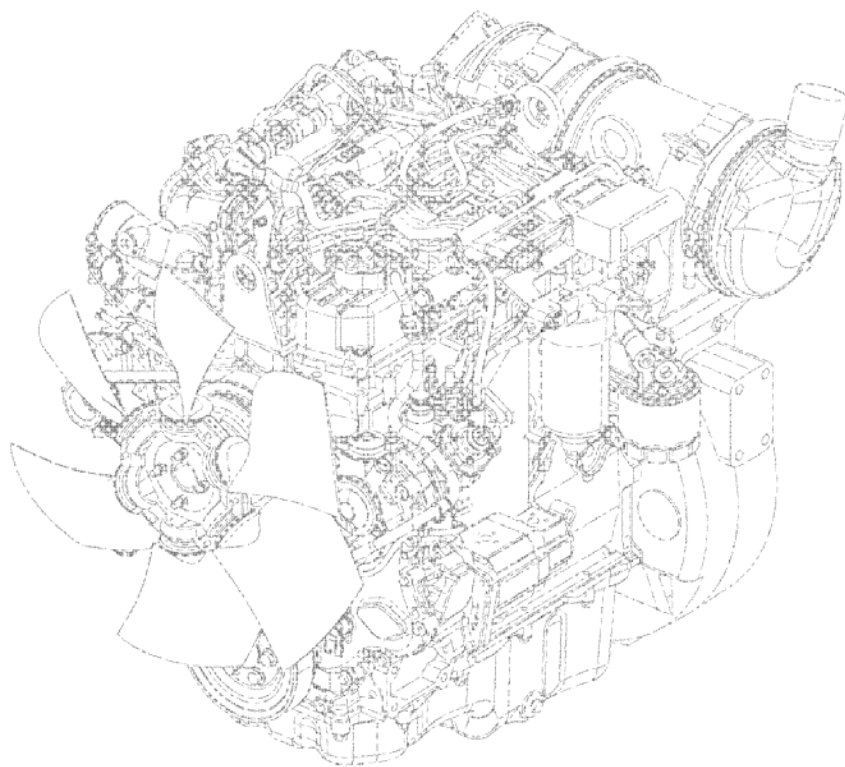

Tav. **D26 06**
Tab.

Validità da matricola / a matricola: **BF08HB1078** /
PIN Nr. from / to :

COD.ORDINE: **411D2606XX**
S/P ORDER :

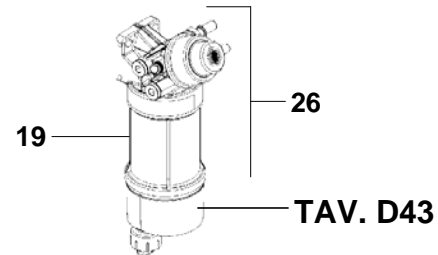
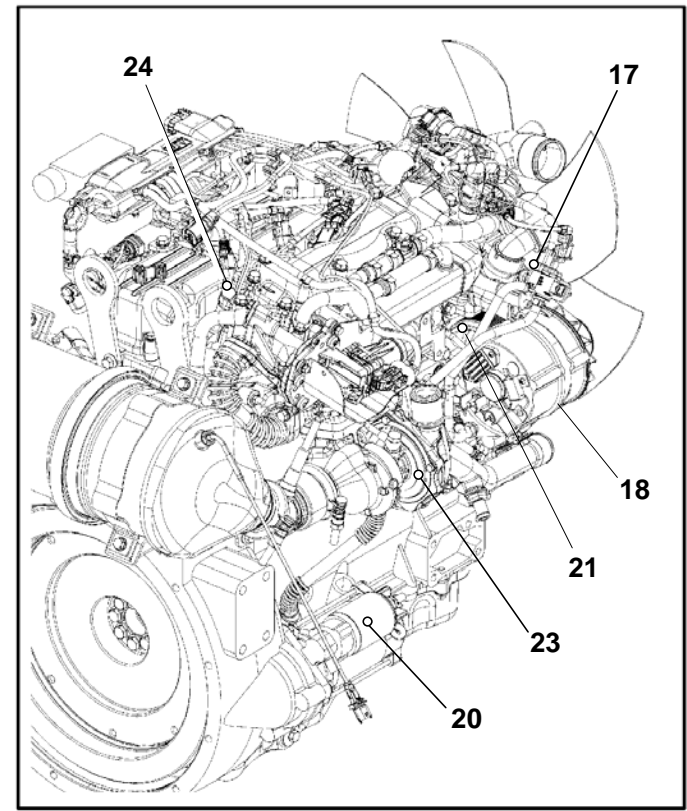
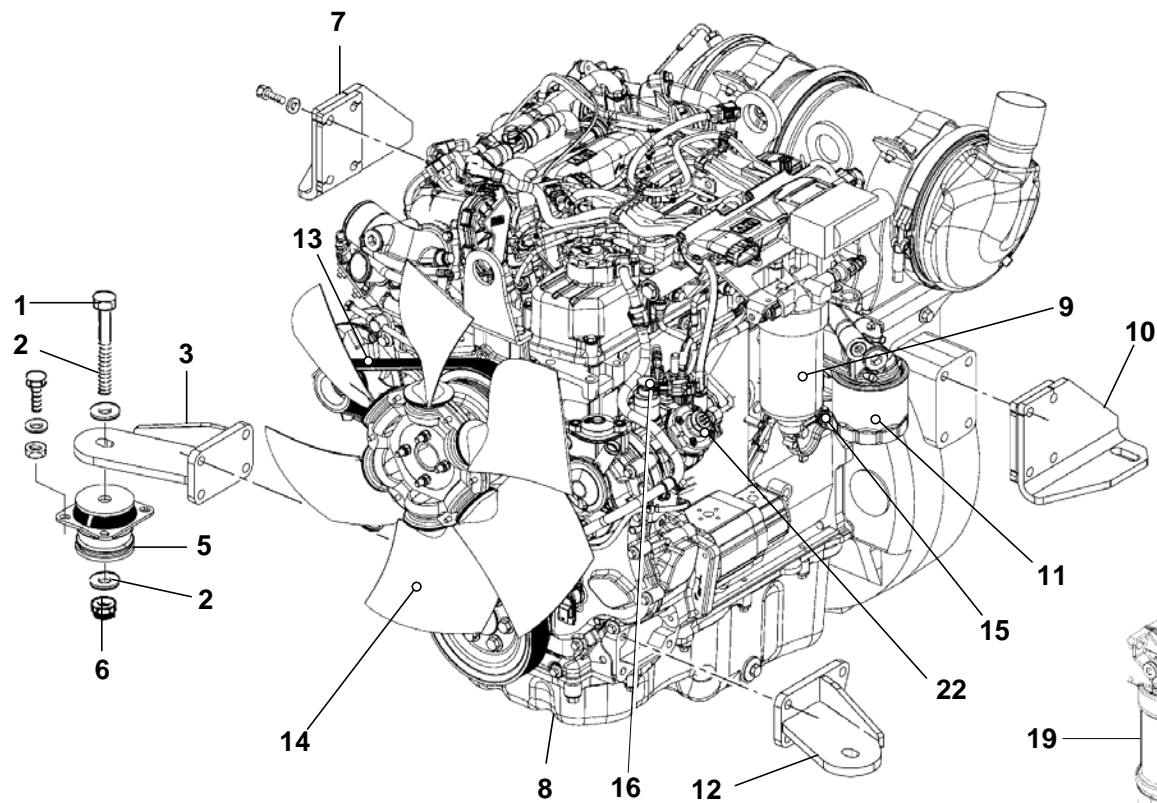

Tav. **D42 08**
 Tab.

Validità da matricola / a matricola: **BF08HB1078** /
 PIN Nr. from / to :

COD.ORDINE: **445D4208XX**
 S/P ORDER :

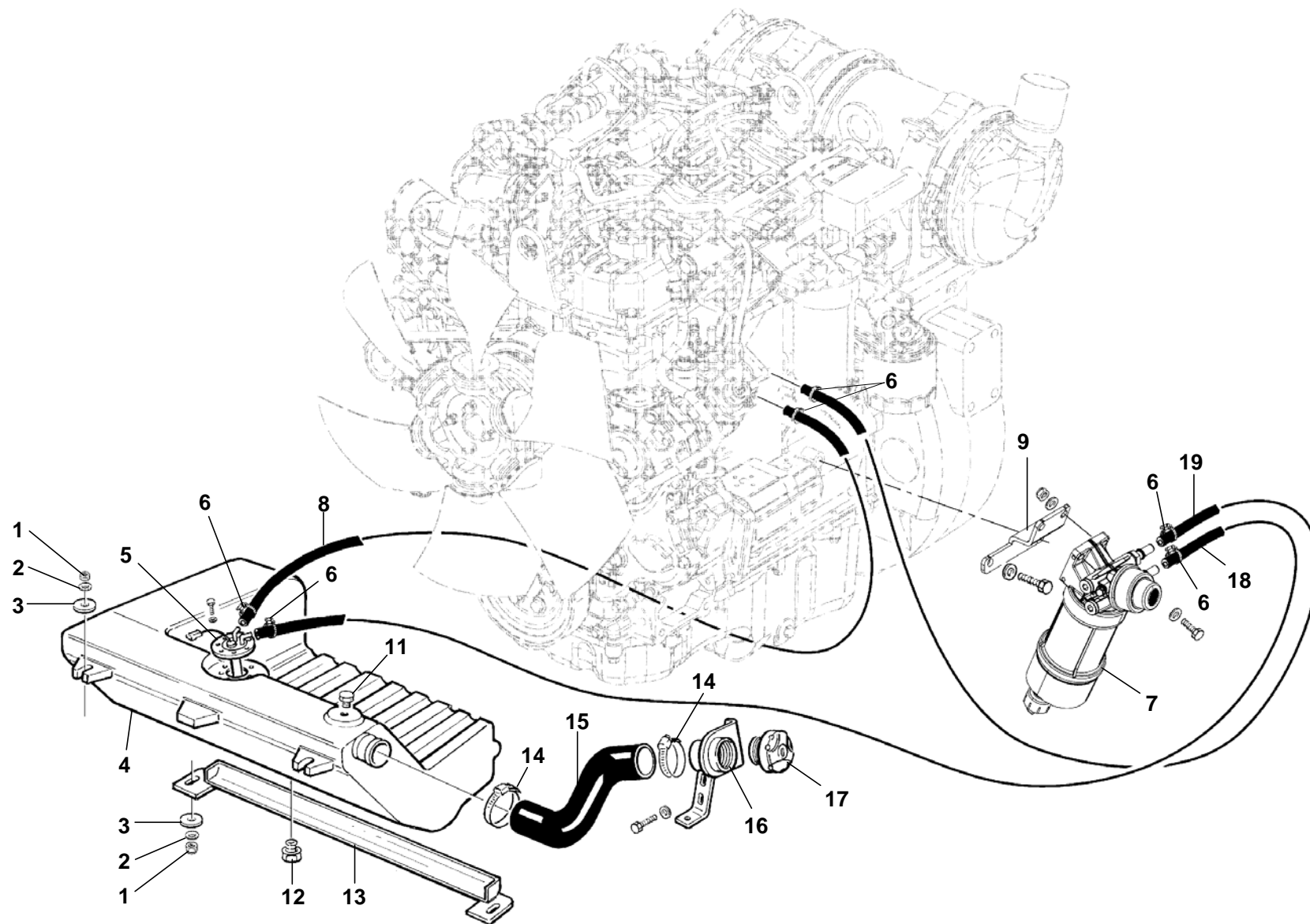

Tav. **D43 03**
 Tab.

Validità da matricola / a matricola: **BF08HB1078** /
 PIN Nr. from / to :

COD.ORDINE: **445D4303XX**
 S/P ORDER :

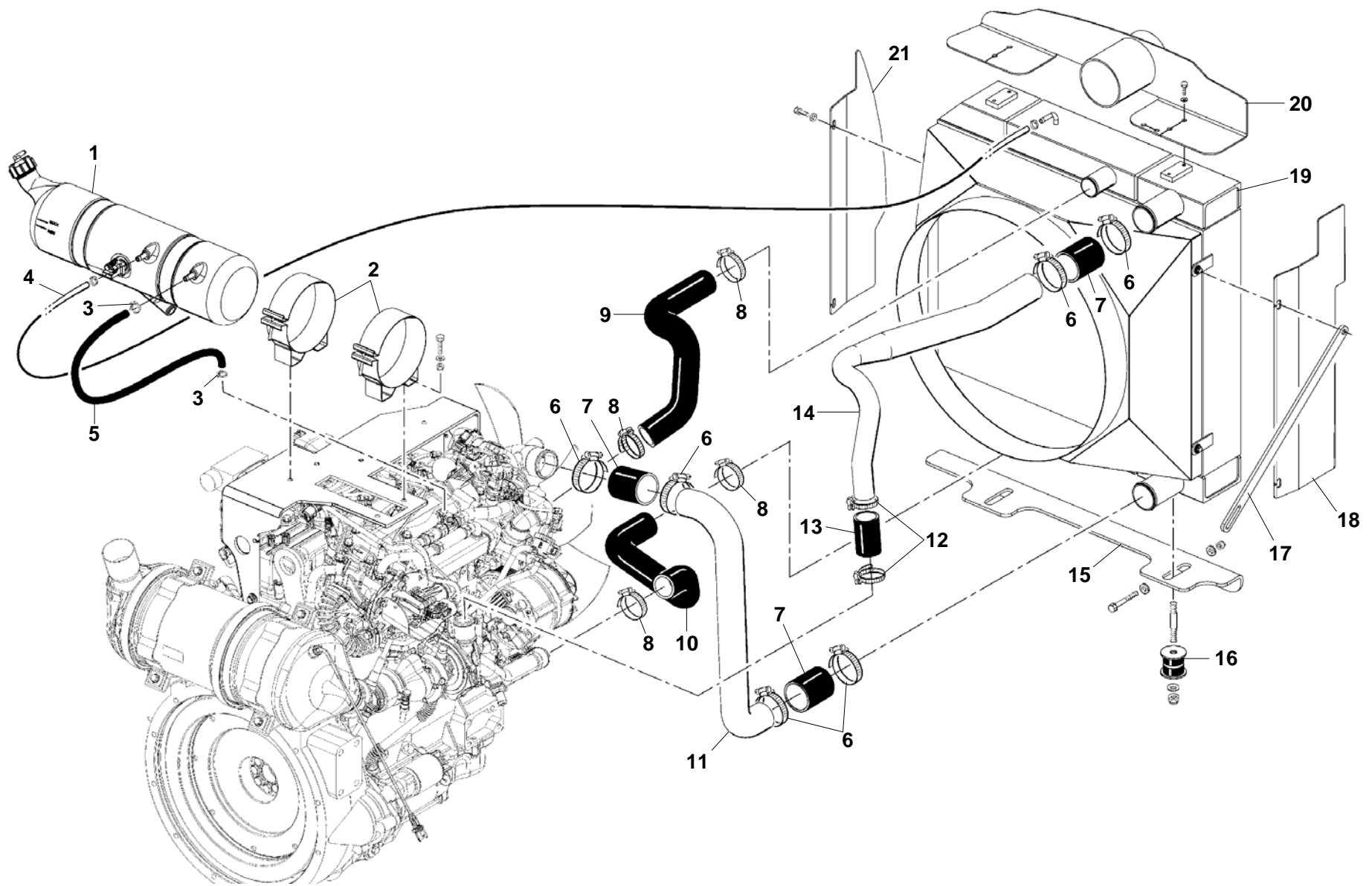

Tav. **D44 04**
 Tab.

Validità da matricola / a matricola: **BF08HB1078** /
 PIN Nr. from / to :

COD.ORDINE: **445D4404XX**
 S/P ORDER :

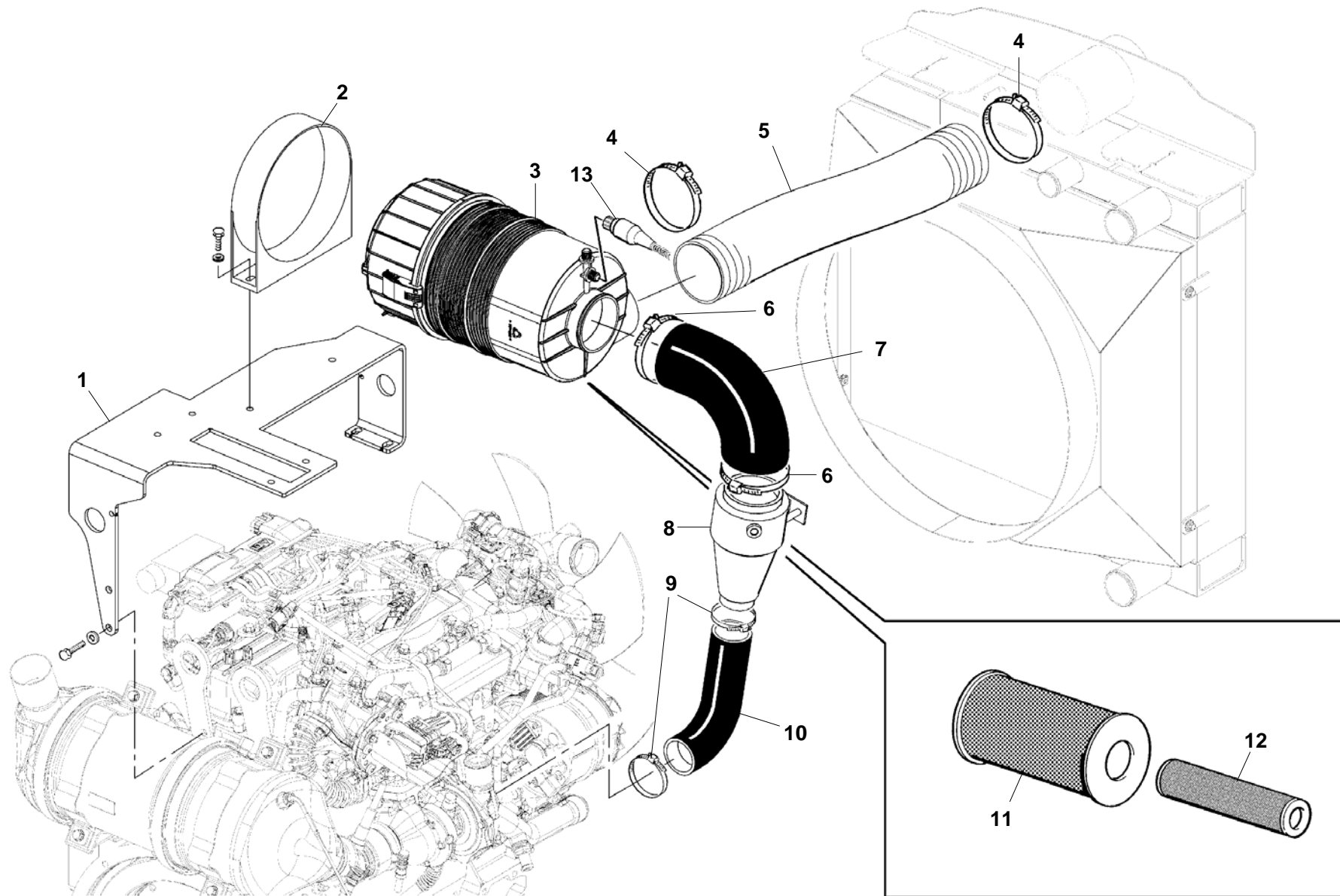

Tav. **D45 04**
 Tab.

Validità da matricola / a matricola: **BF08HB1078** /
 PIN Nr. from / to :

COD.ORDINE: **445D4504XX**
 S/P ORDER :

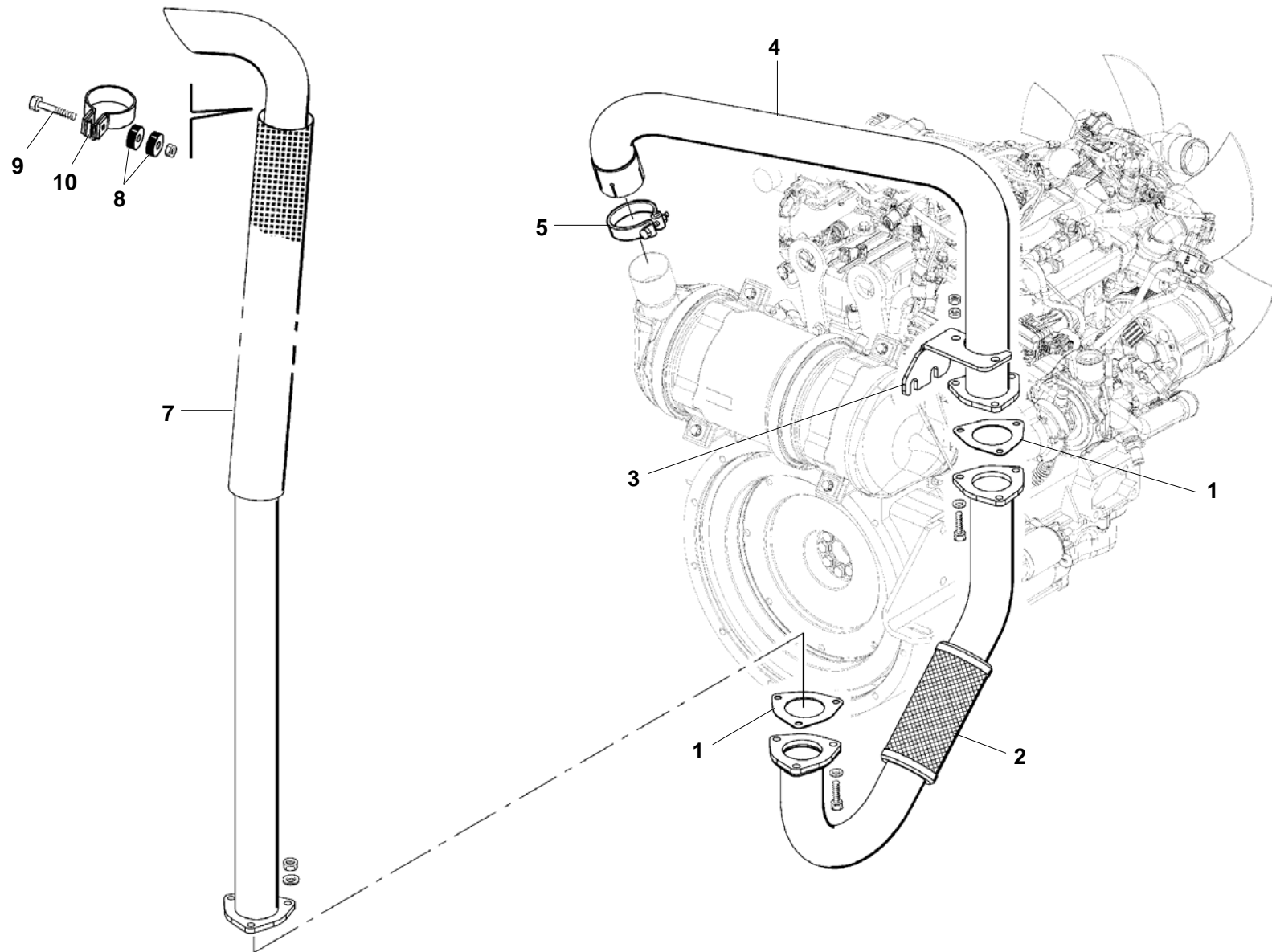

Tav. **D46 02**
 Tab.

Validità da matricola / a matricola: **BF08HB1078** /
 PIN Nr. from / to :

COD.ORDINE: **445D4602XX**
 S/P ORDER :

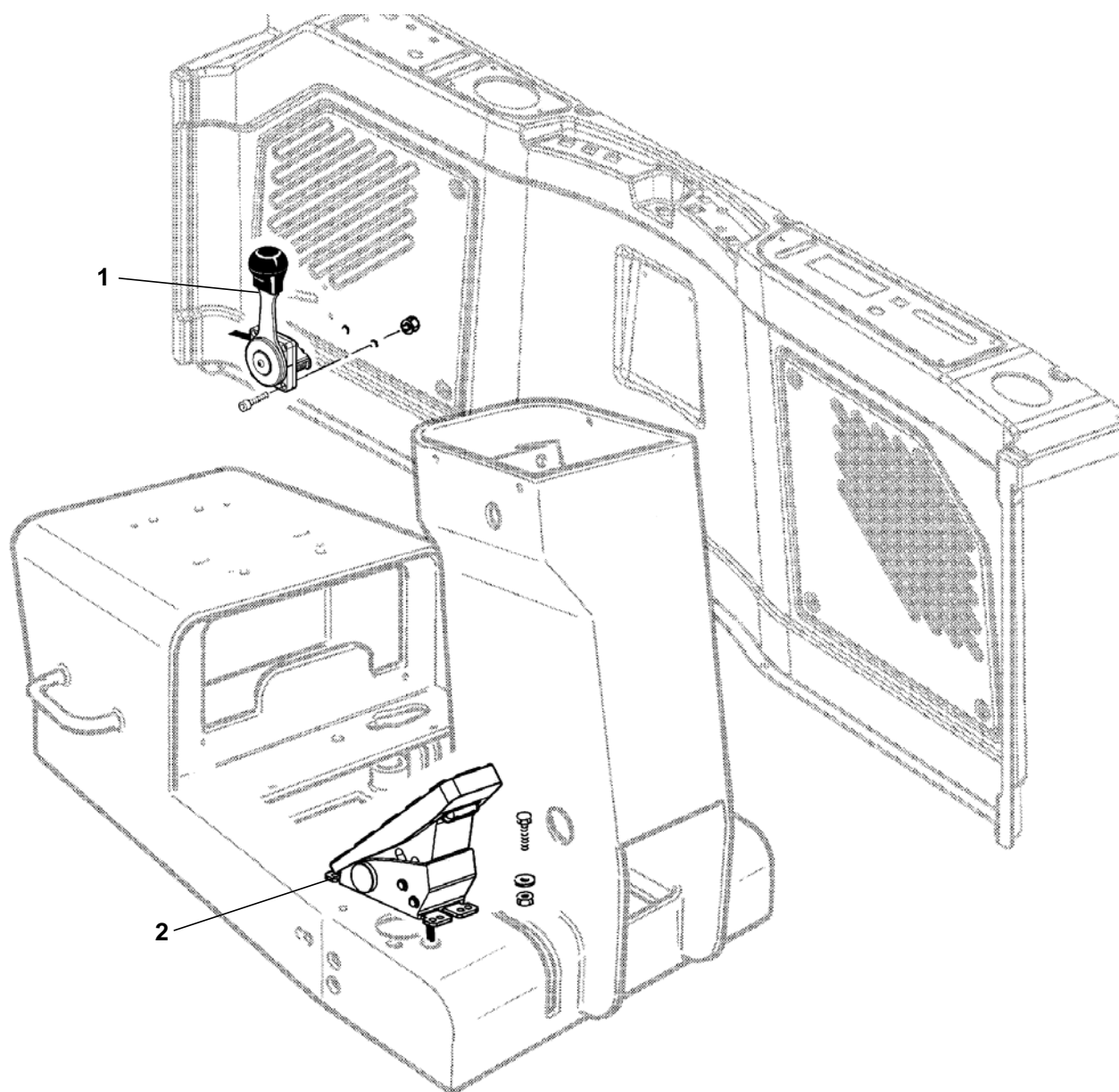

Tav. **D47 03**
Tab.

Validità da matricola / a matricola: **BF08HB1078** /
PIN Nr. from / to :

COD.ORDINE: **445D4703XX**
S/P ORDER :

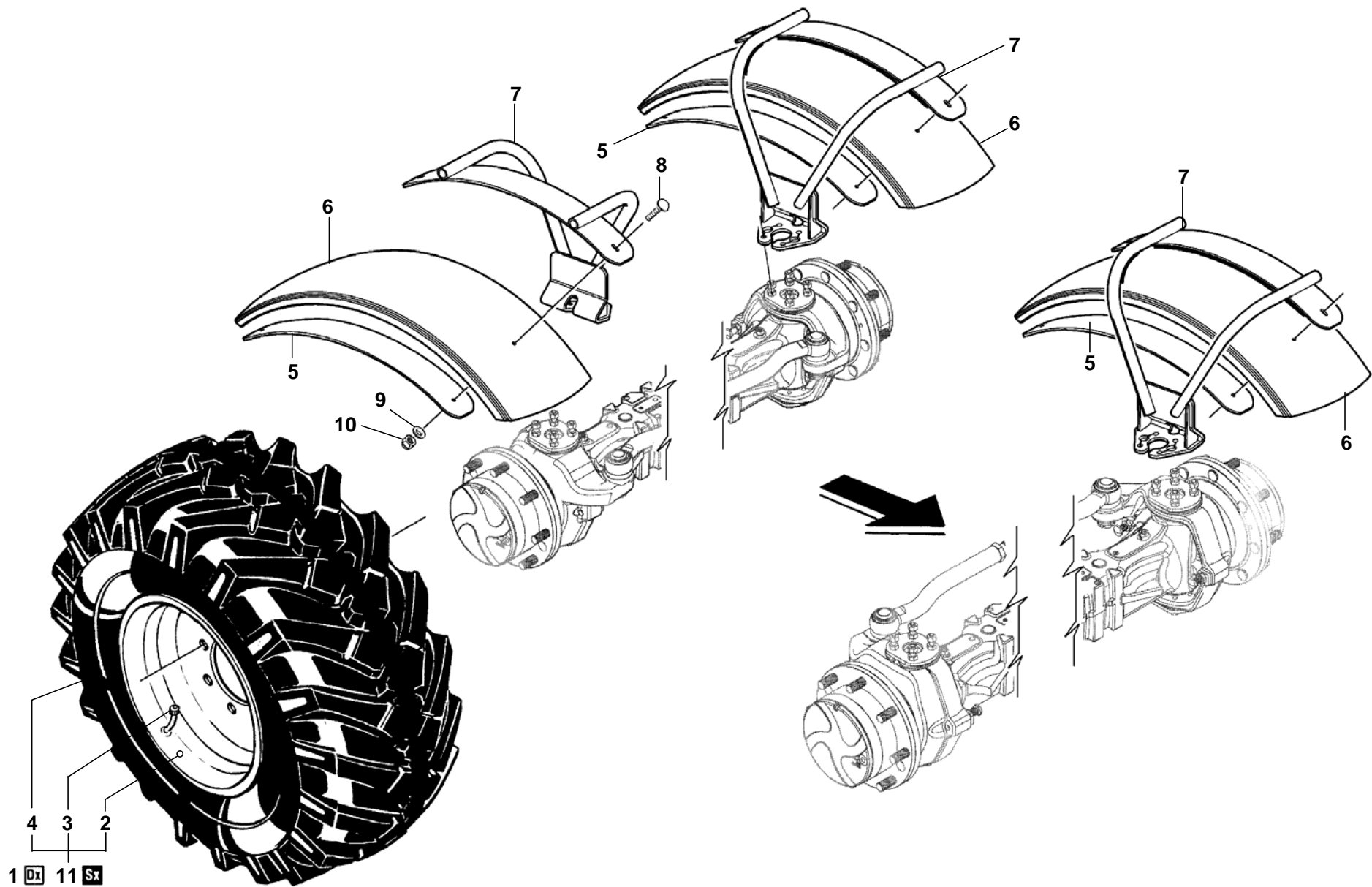

Tav. **E38 03**
 Tab.

Validità da matricola / a matricola: **BF08HB1419** /
 PIN Nr. from / to :

COD.ORDINE: **445E3803XX**
 S/P ORDER :

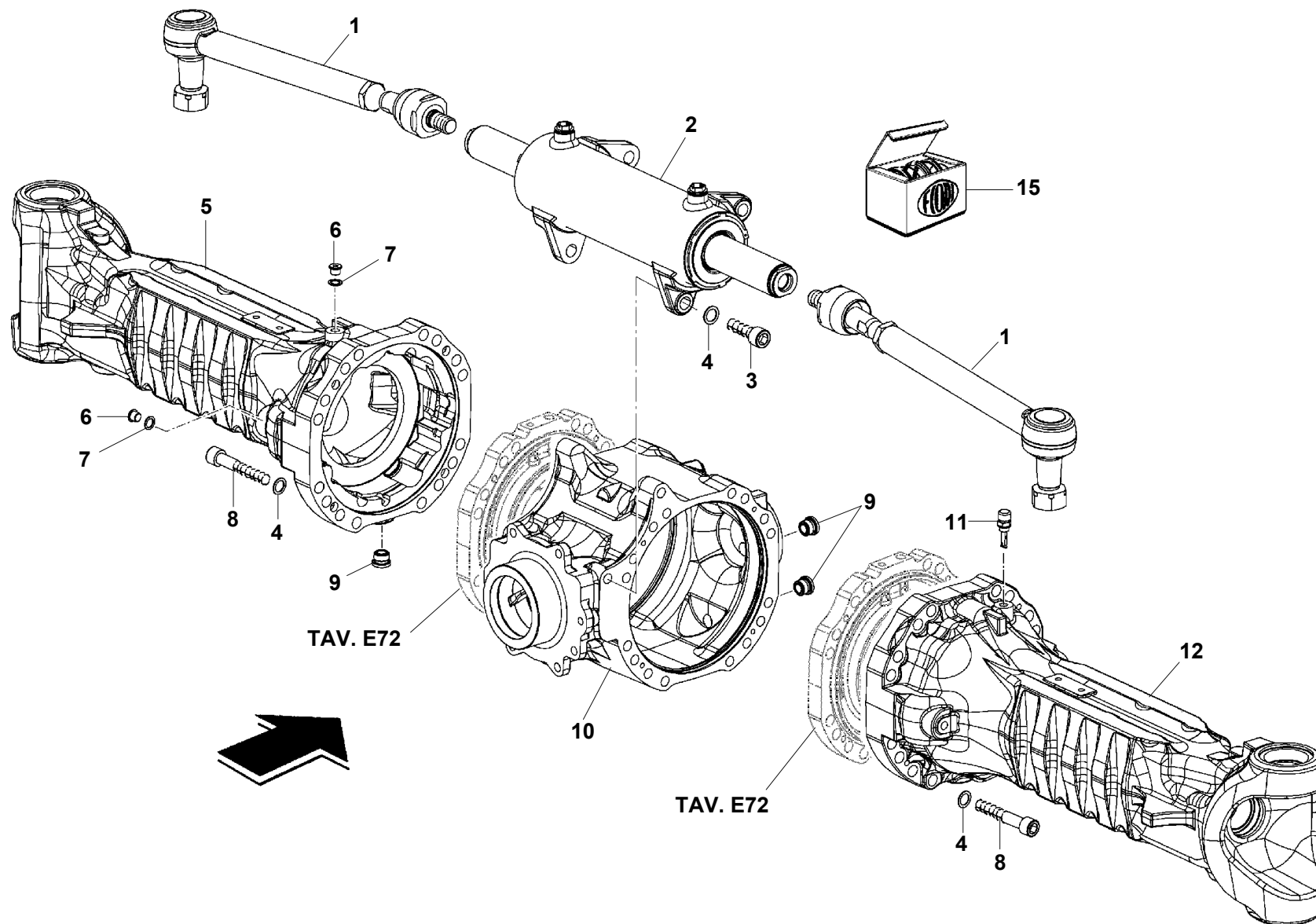

Tav. **E68 00**
 Tab.

Validità da matricola / a matricola: **BF08HB1222** /
 PIN Nr. from / to :

COD.ORDINE: **445E6800XX**
 S/P ORDER :

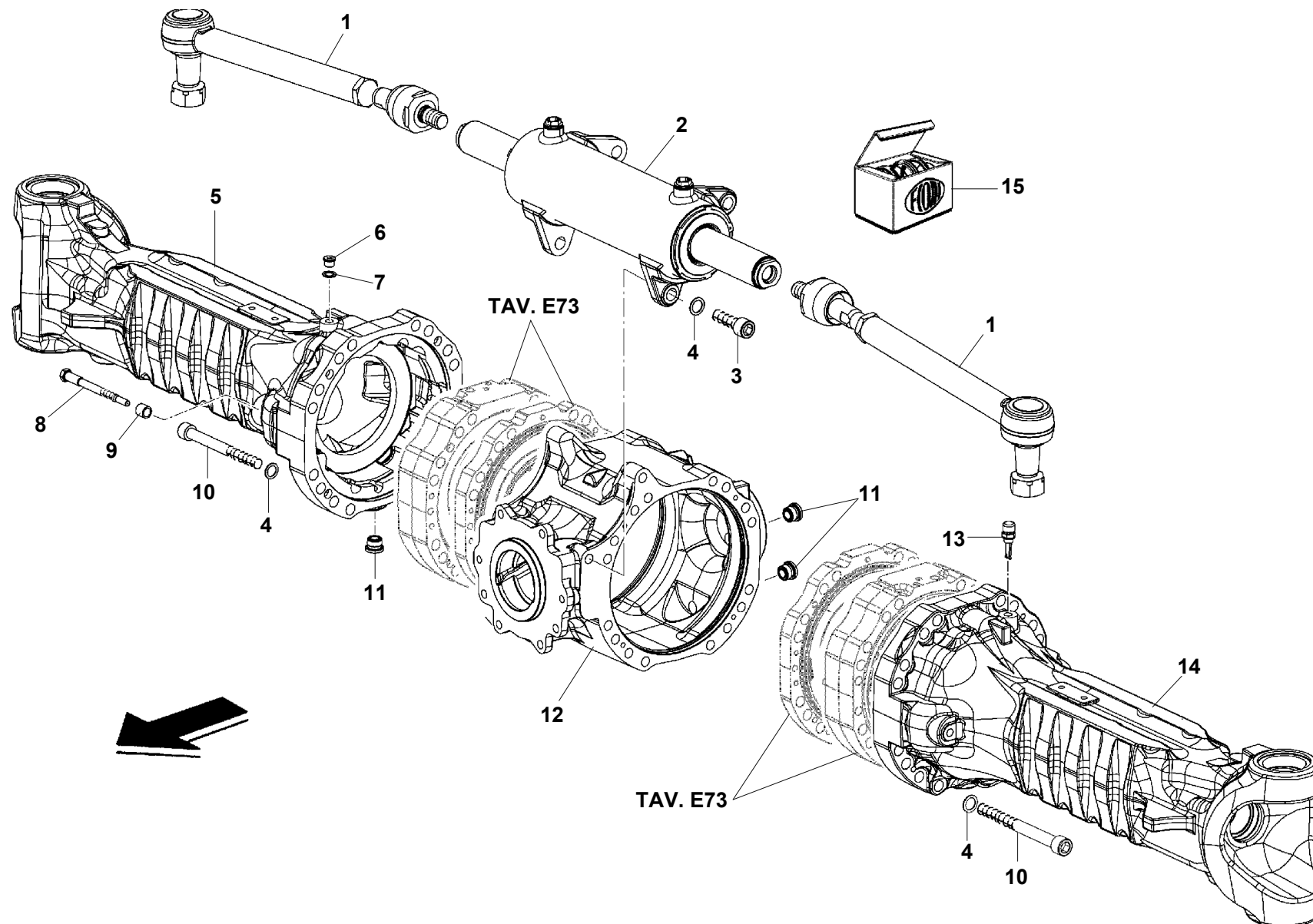

Tav. **E69 00**
Tab.

Validità da matricola / a matricola: **BF08HB1222** /
PIN Nr. from / to :

COD.ORDINE: **445E6900XX**
S/P ORDER :

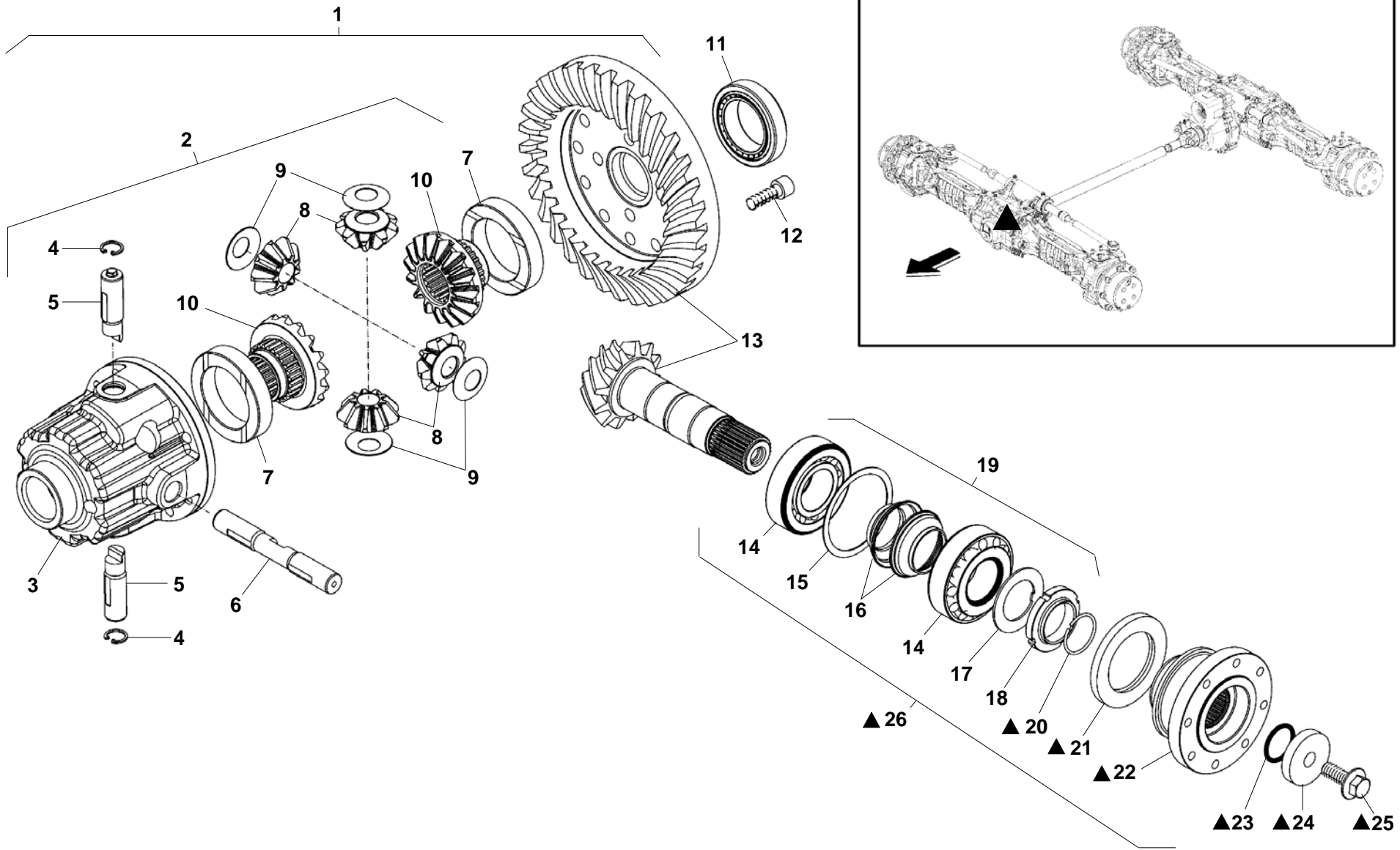

Tav. **E70 00**
 Tab.

Validità da matricola / a matricola: **BF08HB1222** /
 PIN Nr. from / to :

COD.ORDINE: **445E7000XX**
 S/P ORDER :

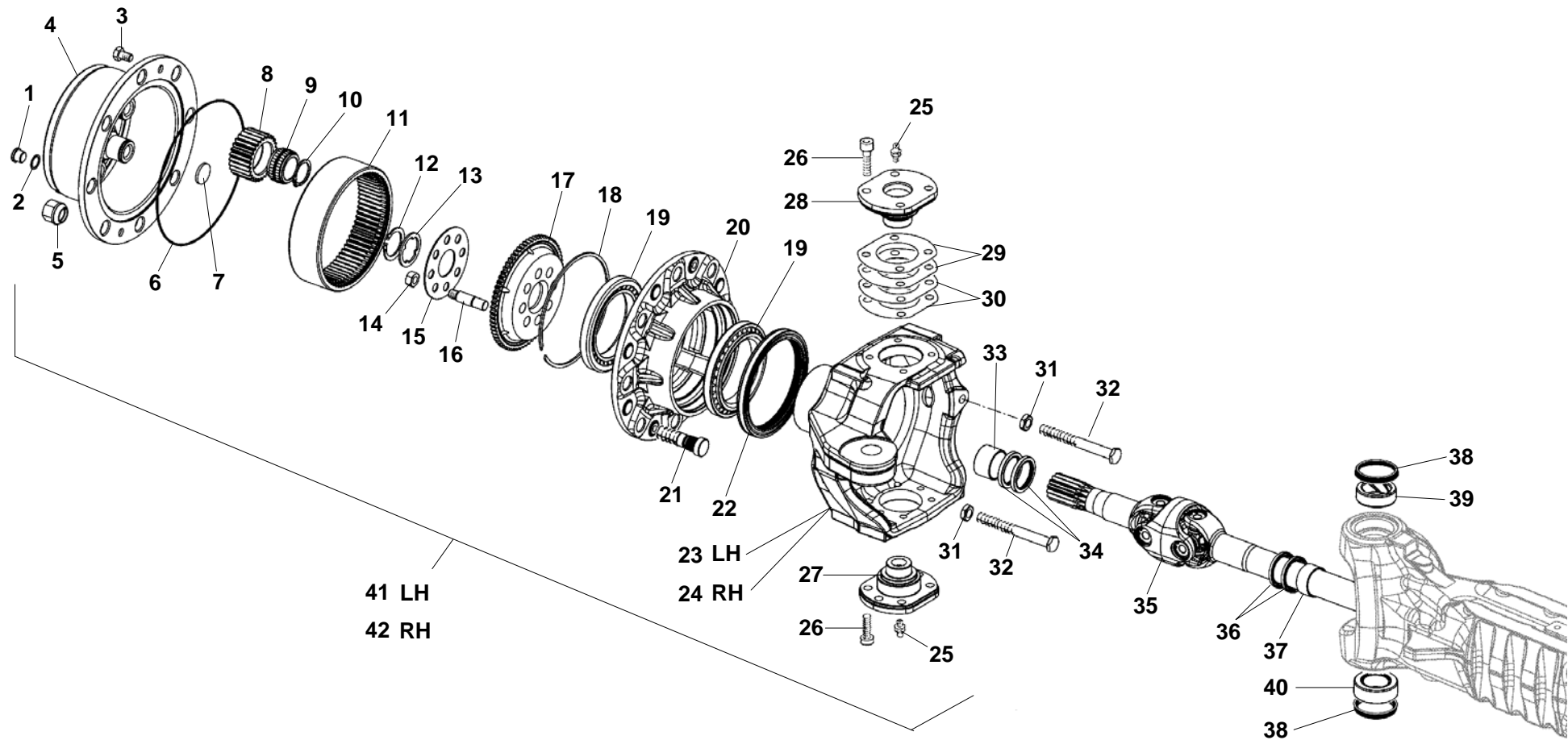

Tav. **E71 00**
 Tab.

Validità da matricola / a matricola: **BF08HB1222** /
 PIN Nr. from / to :

COD.ORDINE: **445E7100XX**
 S/P ORDER :

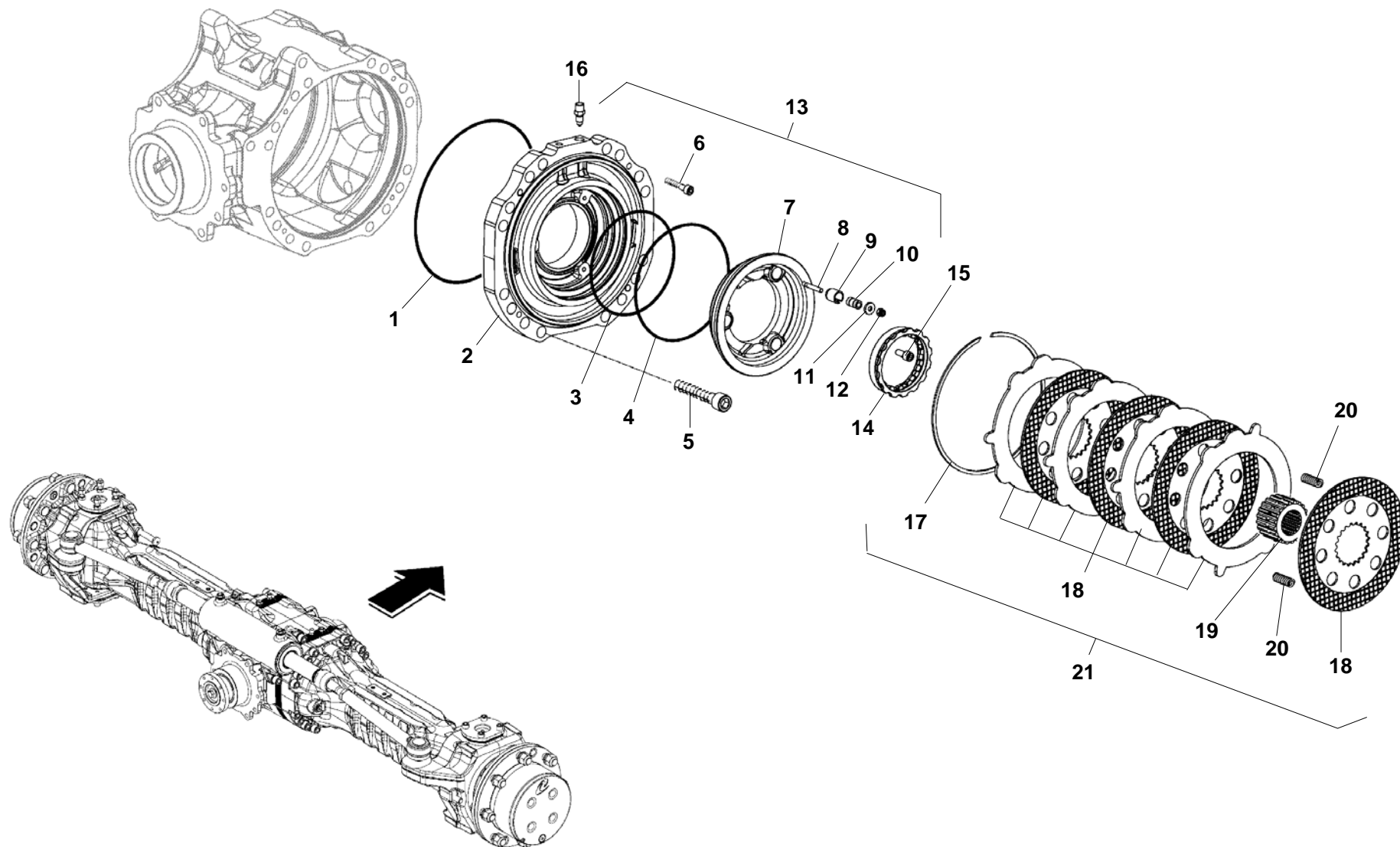

Tav. **E72 00**
 Tab.

Validità da matricola / a matricola: **BF08HB1222** /
 PIN Nr. from / to :

COD.ORDINE: **445E7200XX**
 S/P ORDER :

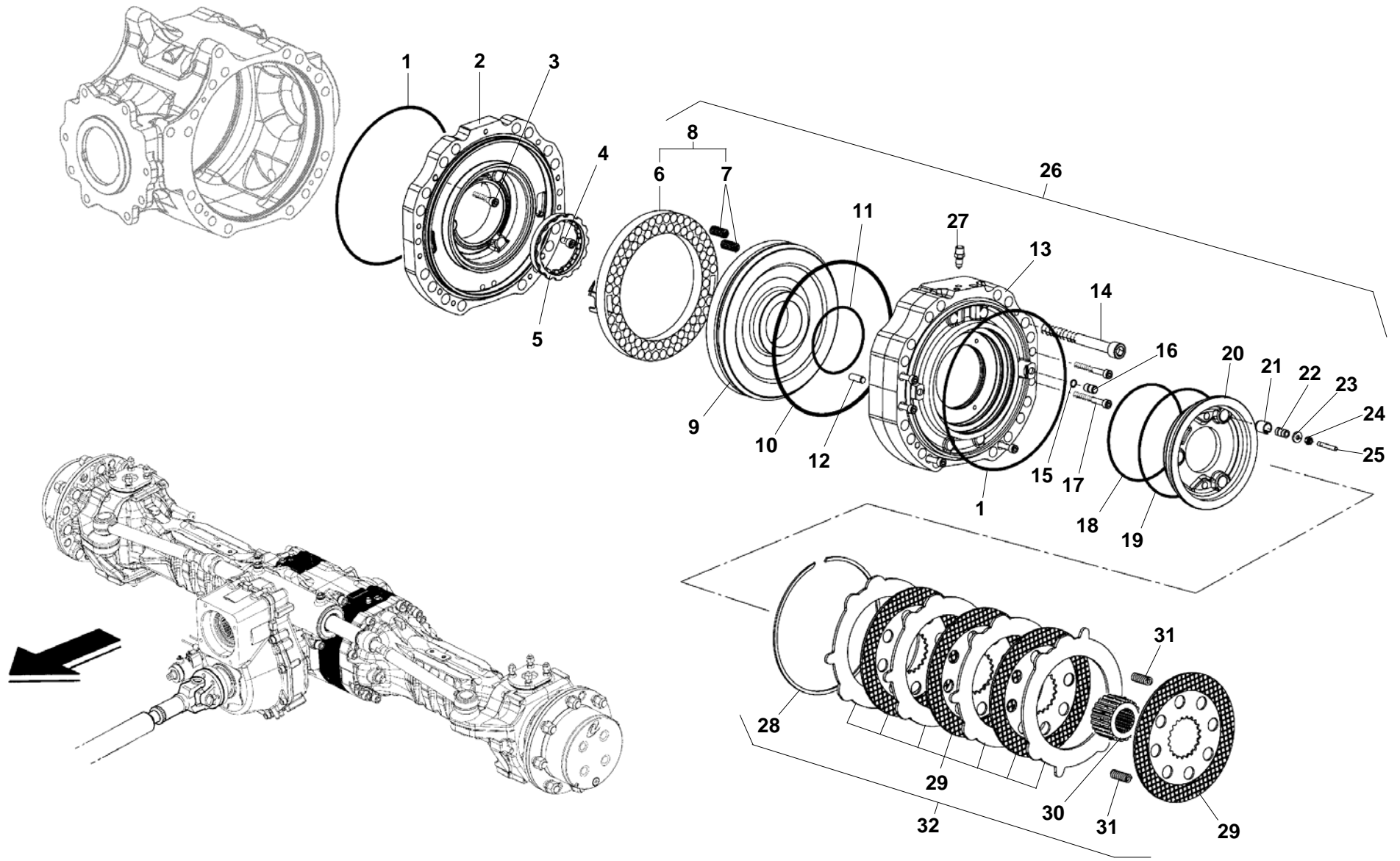

Tav. **E73 00**
 Tab.

Validità da matricola / a matricola: **BF08HB1222 /**
 PIN Nr. from / to :

COD.ORDINE: **445E7300XX**
 S/P ORDER :

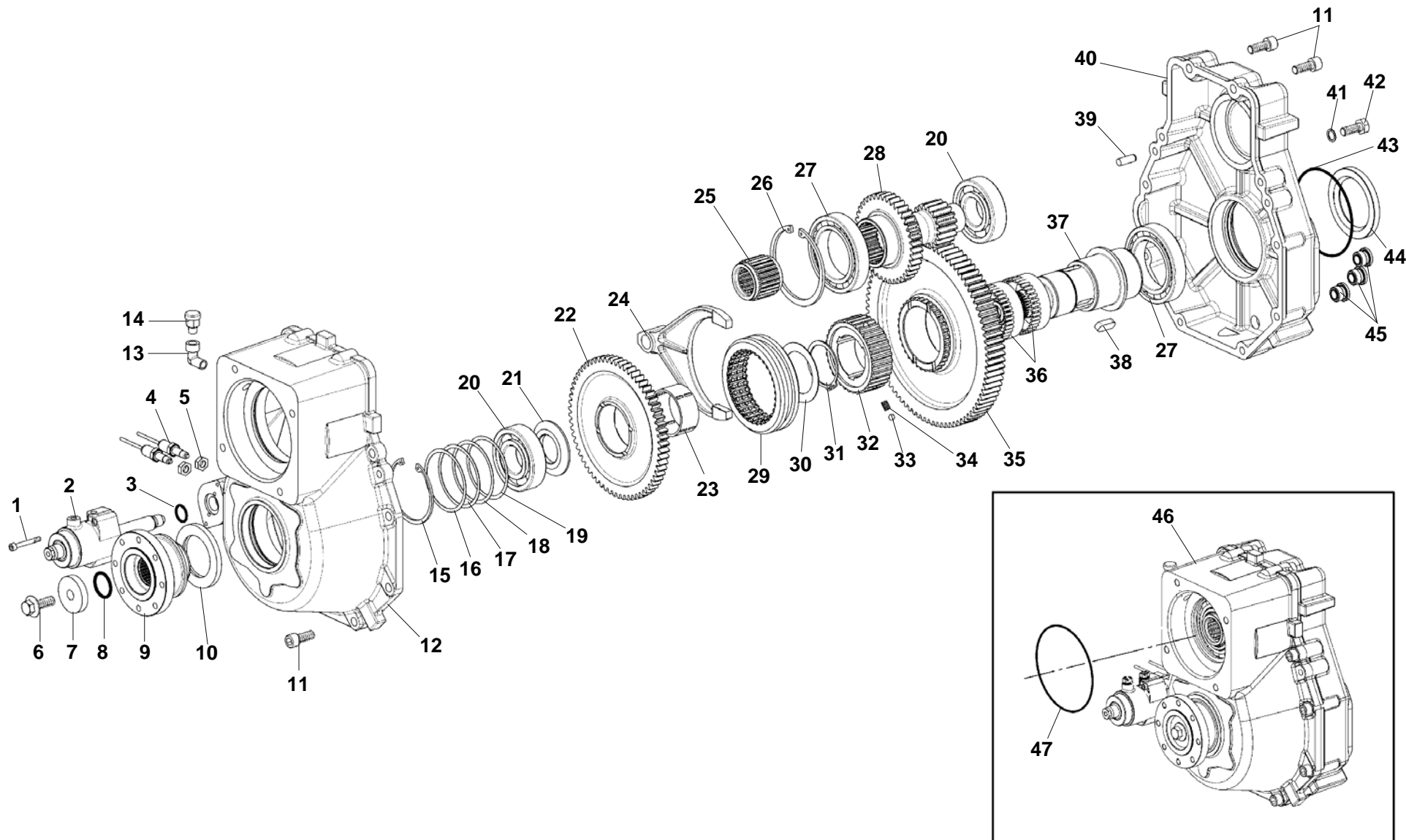

Tav. **E74 00**
 Tab.

Validità da matricola / a matricola: **BF08HB1222** /
 PIN Nr. from / to :

COD.ORDINE: **445E7400XX**
 S/P ORDER :

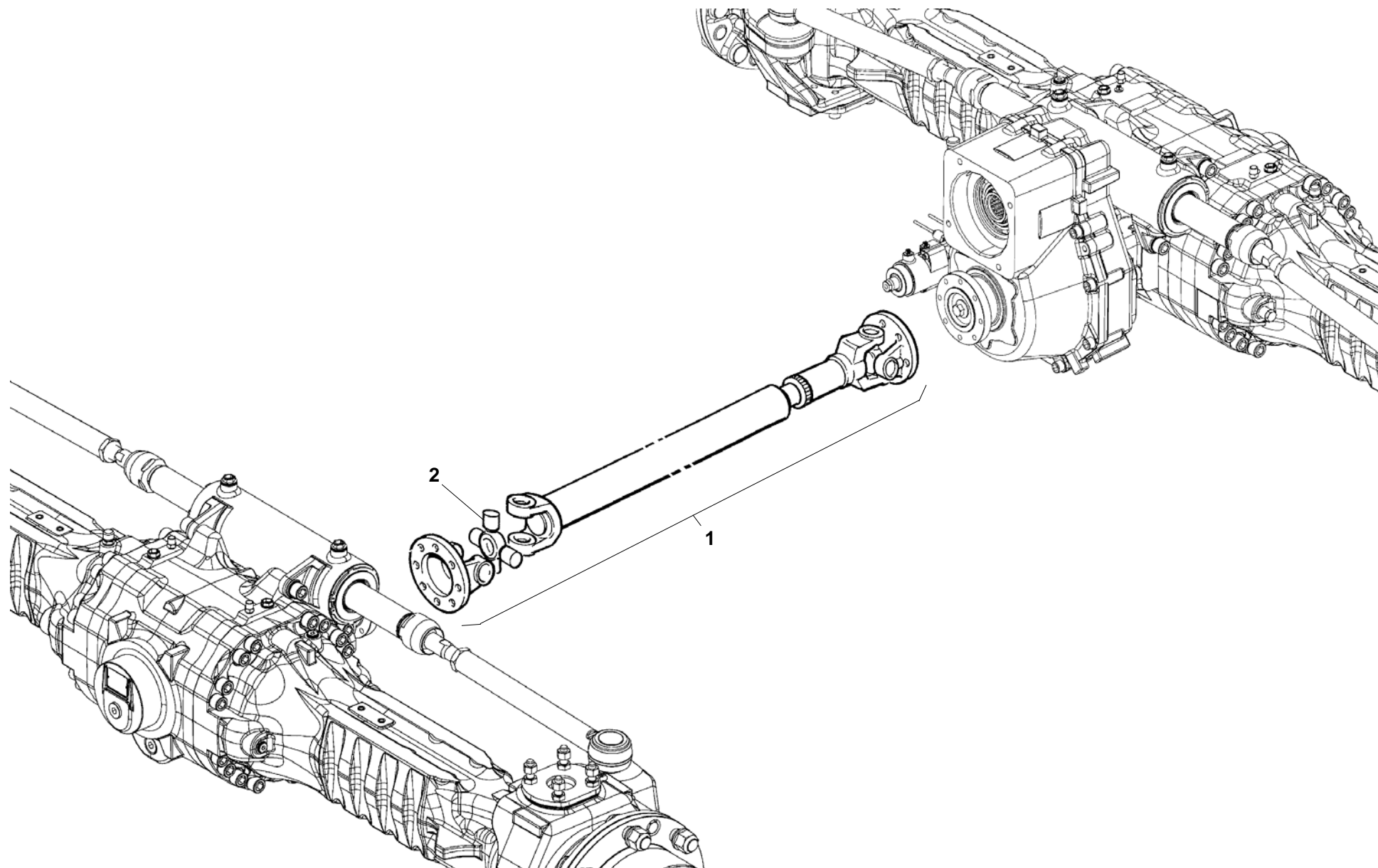

Tav. **E75 00**
Tab.

Validità da matricola / a matricola: **BF08HB1222** /
PIN Nr. from / to :

COD.ORDINE: **445E7500XX**
S/P ORDER :

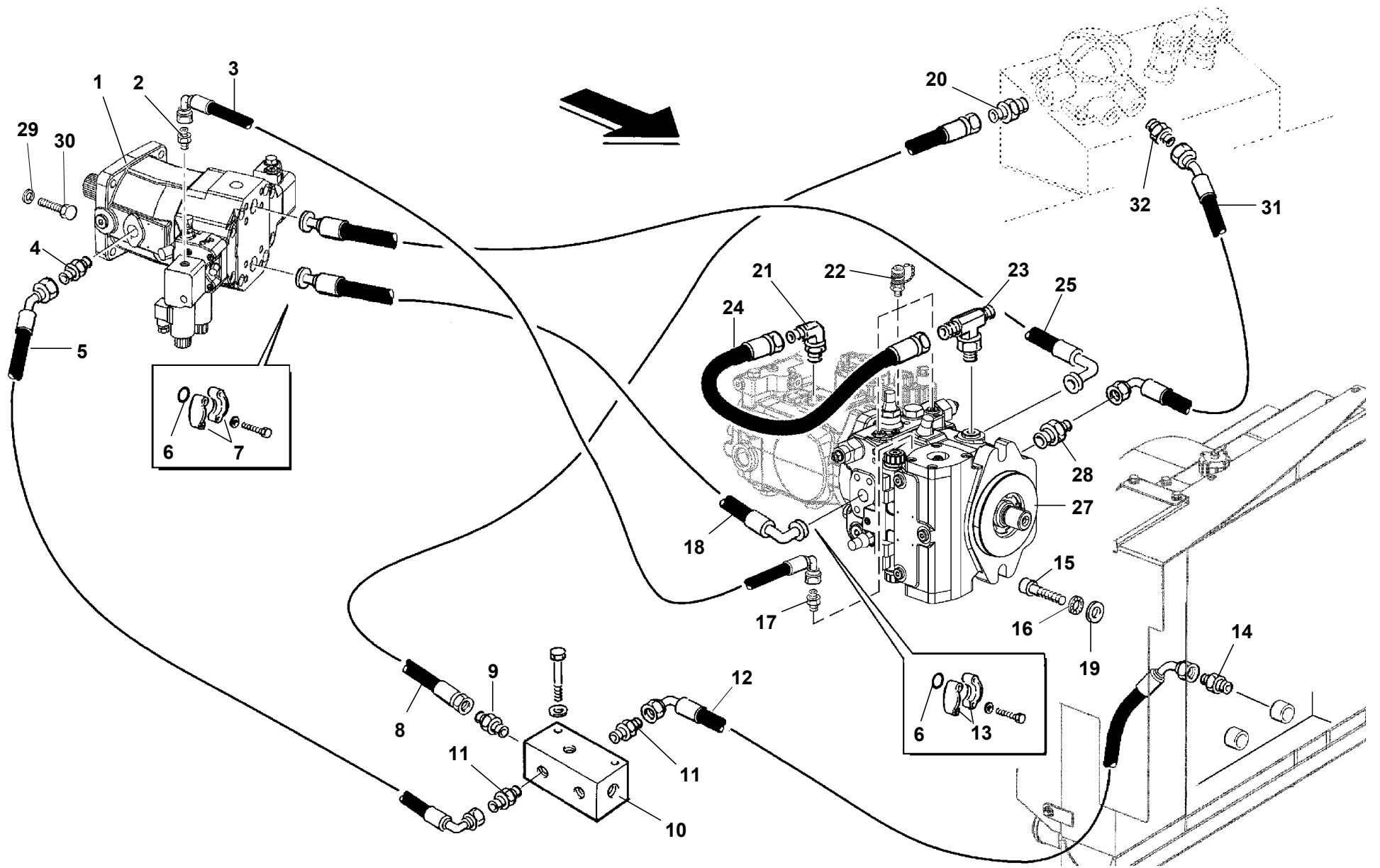

Tav. **F11 13**
 Tab.

Validità da matricola / a matricola: **BF08HB1404** /
 PIN Nr. from / to :

COD.ORDINE: **445F1113XX**
 S/P ORDER :

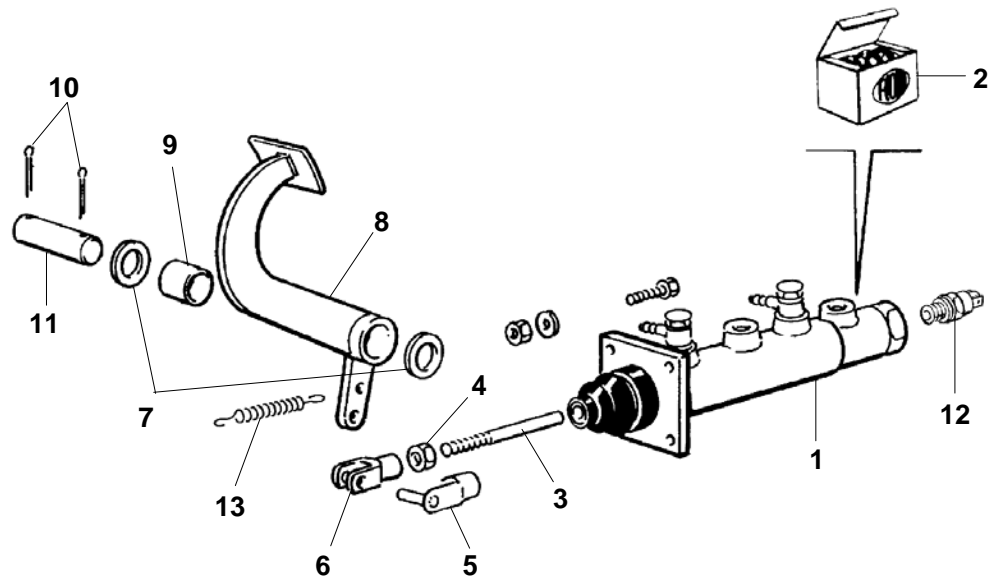

Tav. **G17 04**
Tab.

Validità da matricola / a matricola: **BF08HB1380** /
PIN Nr. from / to :

COD.ORDINE: **445G1704XX**
S/P ORDER :

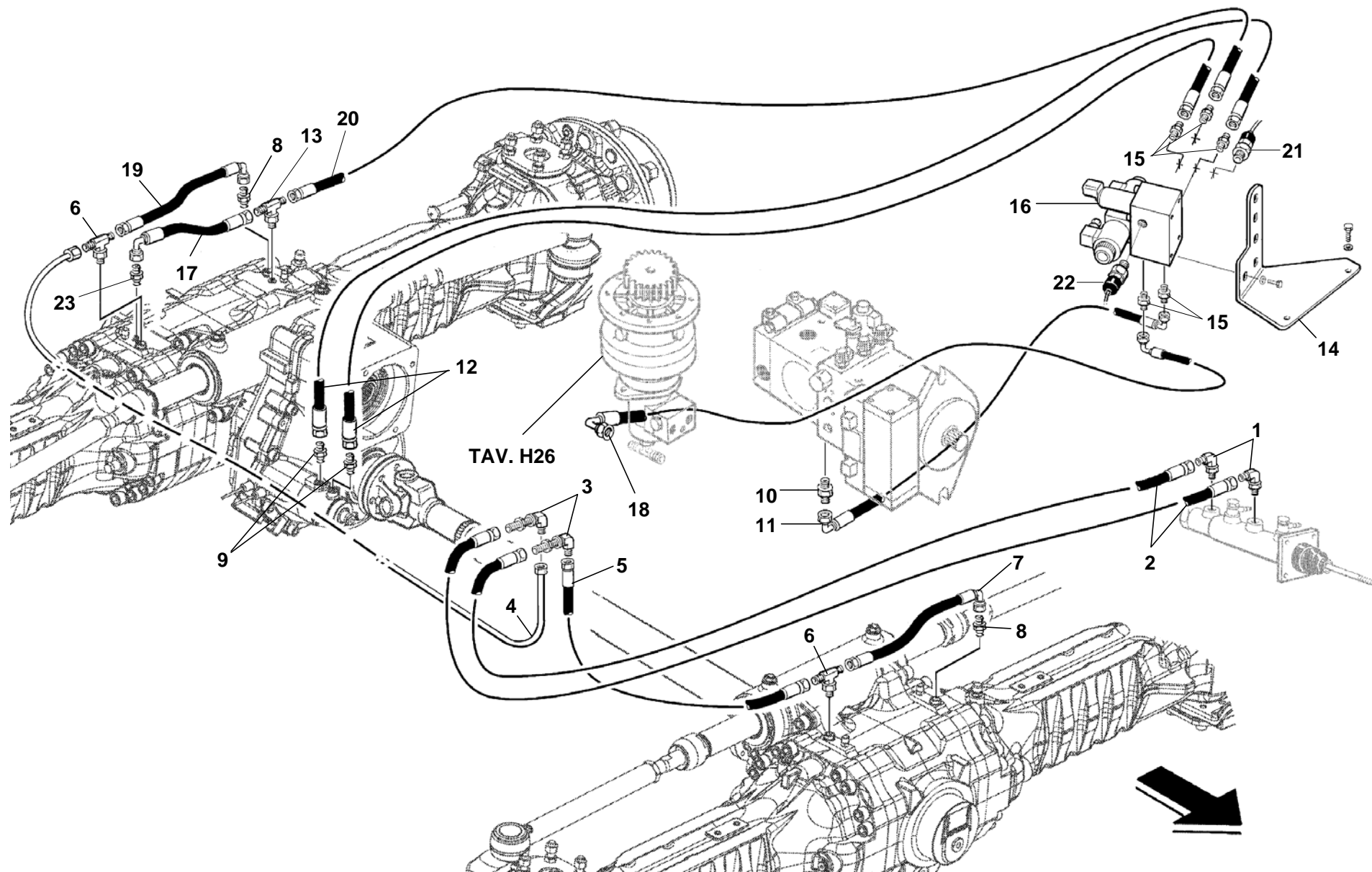

Tav. **G20 03**
 Tab.

Validità da matricola / a matricola: **BF08HB1222** /
 PIN Nr. from / to :

COD.ORDINE: **445G2003XX**
 S/P ORDER :

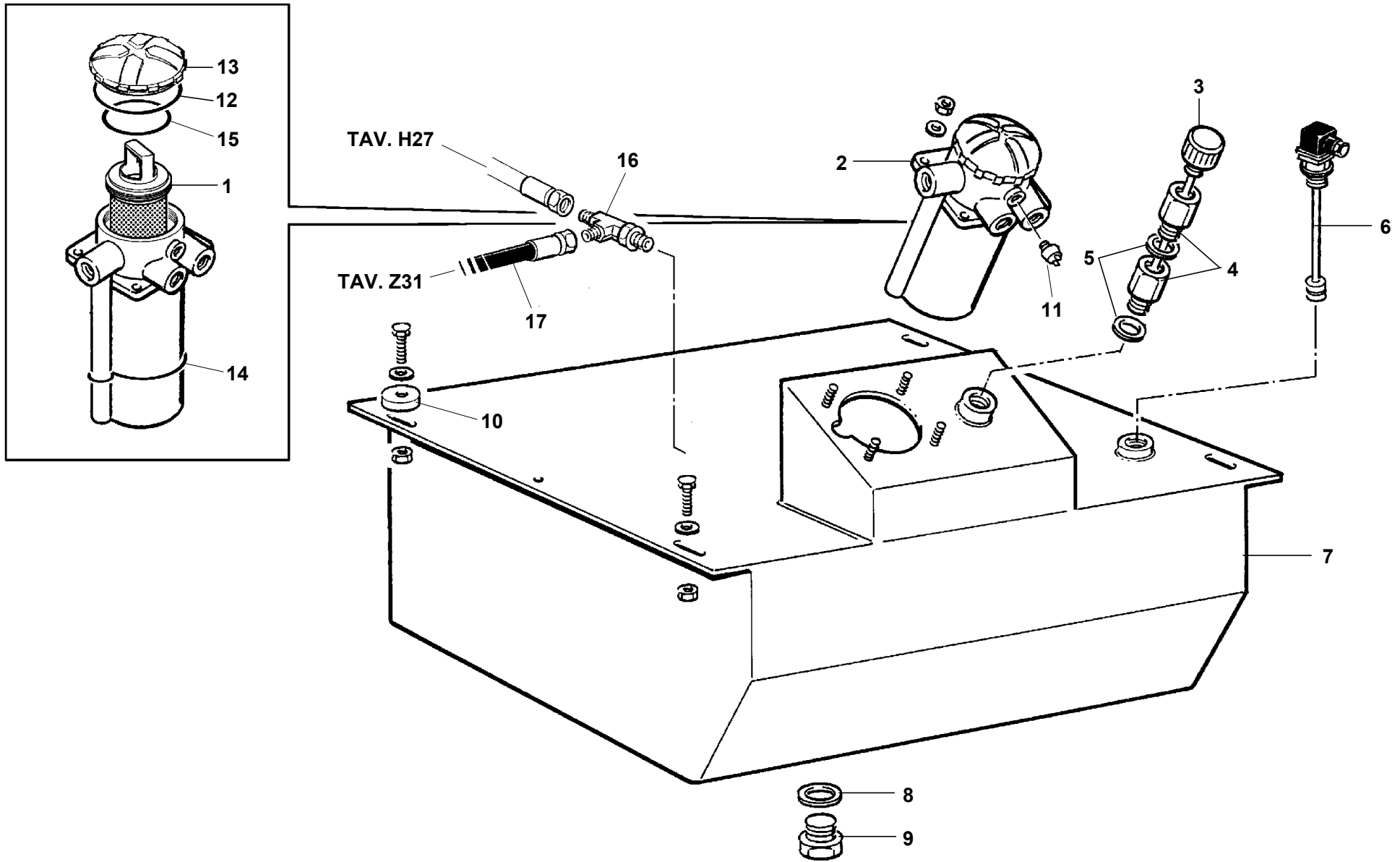

Tav. **H20 03**
 Tab.

Validità da matricola / a matricola: **BF08HB1510** /
 PIN Nr. from / to :

COD.ORDINE: **445H2003XX**
 S/P ORDER :

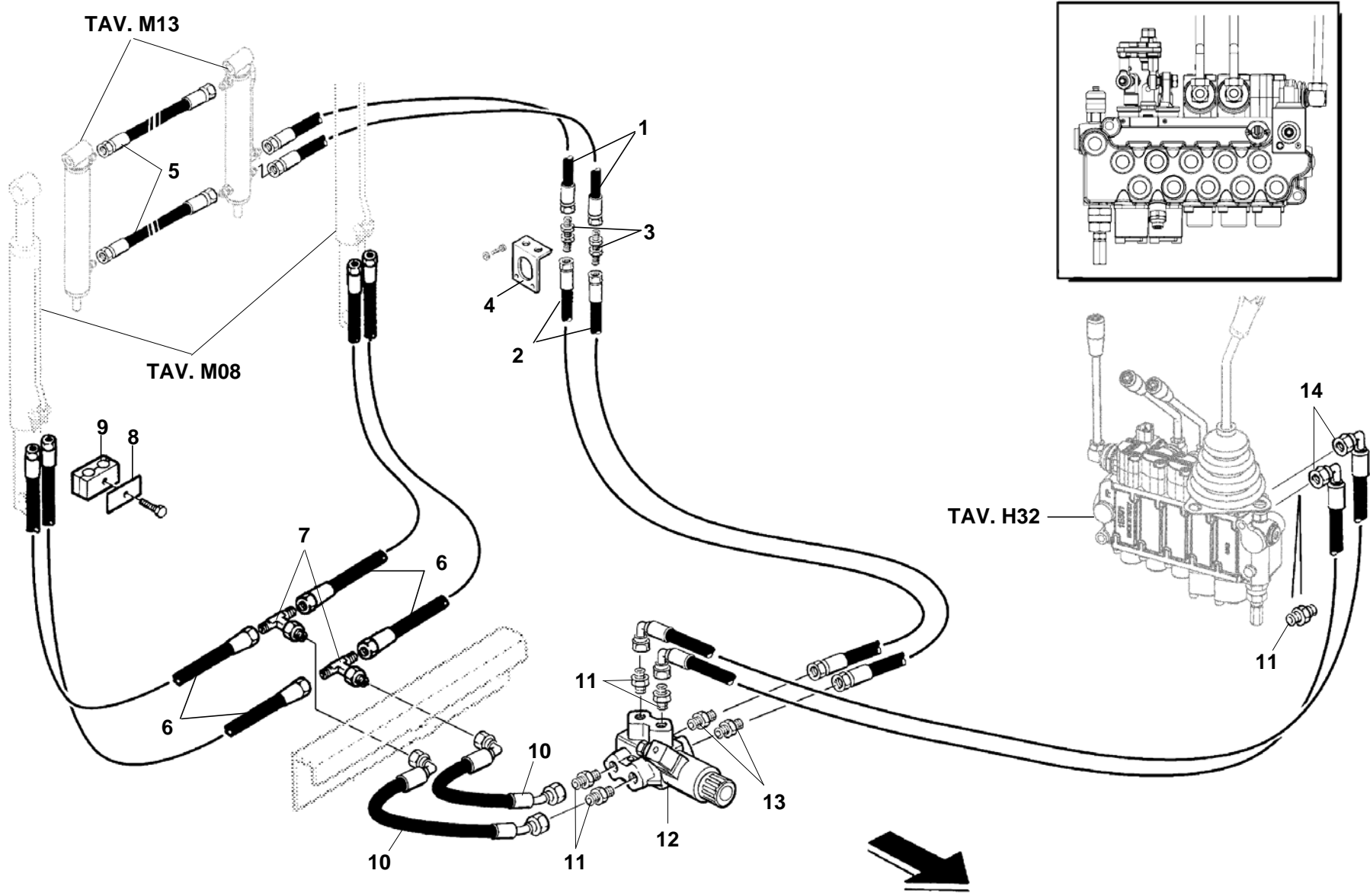

Tav. **H23 02**
 Tab.

Validità da matricola / a matricola: **BF08HB1354** /
 PIN Nr. from / to :

COD.ORDINE: **445H2302XX**
 S/P ORDER :

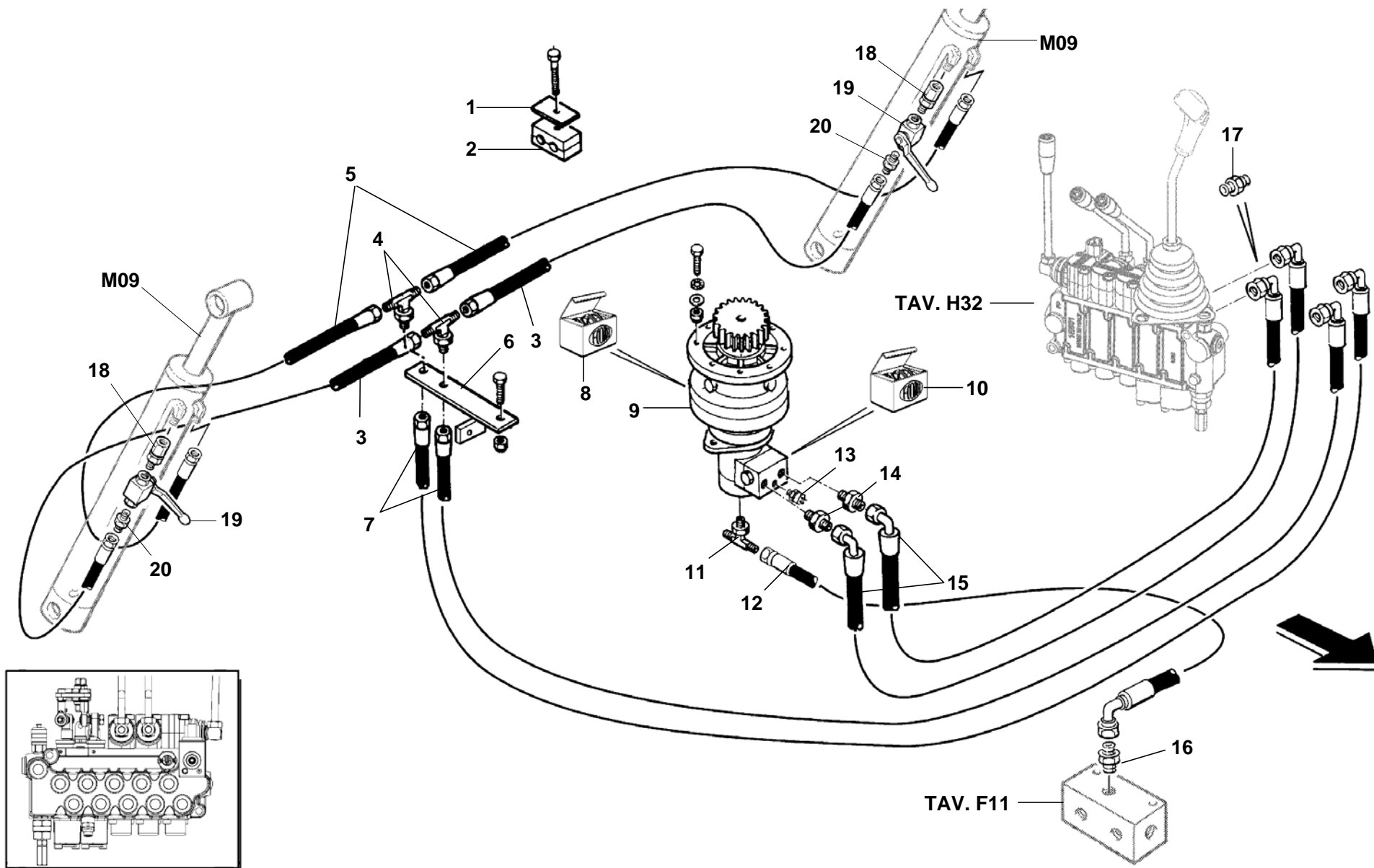

Tav. **H26 05**
Tab.

Validità da matricola / a matricola: **BF08HB1354** /
PIN Nr. from / to :

COD.ORDINE: **445H2605XX**
S/P ORDER :

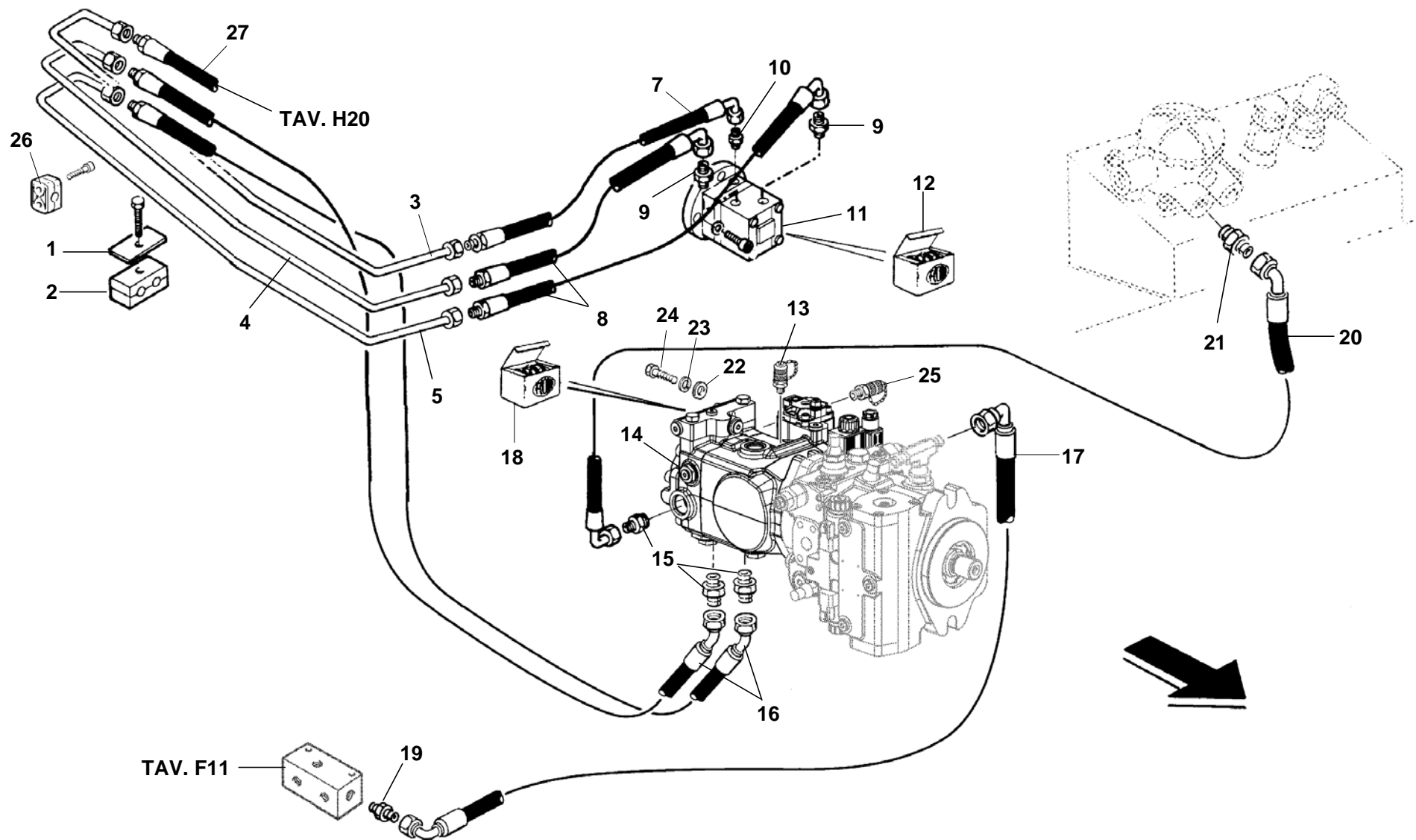

Tav. **H27 04**
 Tab.

Validità da matricola / a matricola: **BF08HB1078** /
 PIN Nr. from / to :

COD.ORDINE: **445H2704XX**
 S/P ORDER :

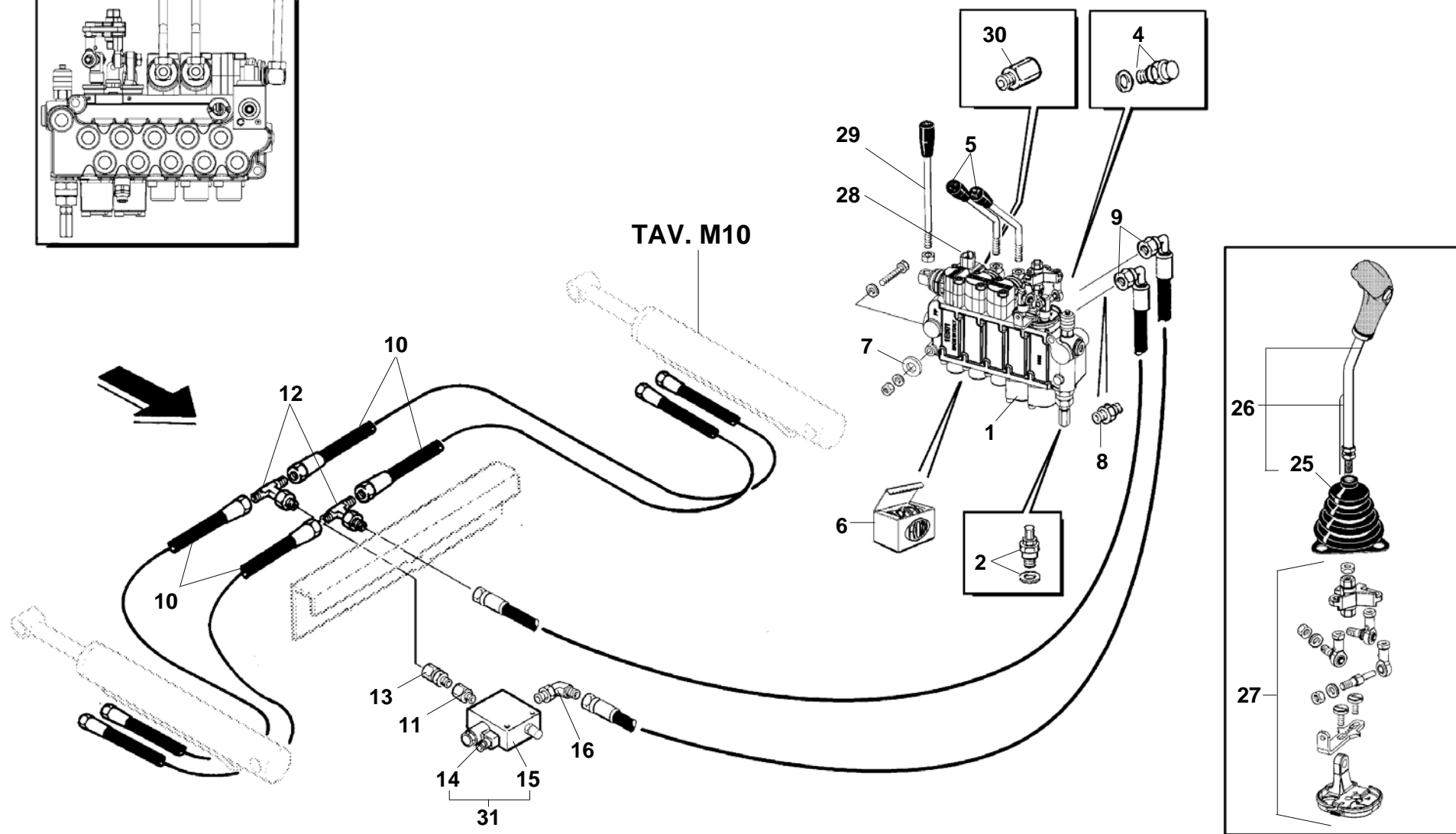
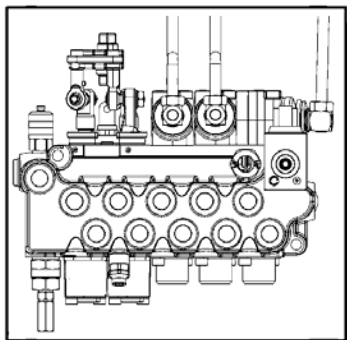

Tav.
Tab. **H32 07**

Validità da matricola / a matricola: **BF08HB1427** /
PIN Nr. from / to :

COD.ORDINE: **445H3207XX**
S/P ORDER :

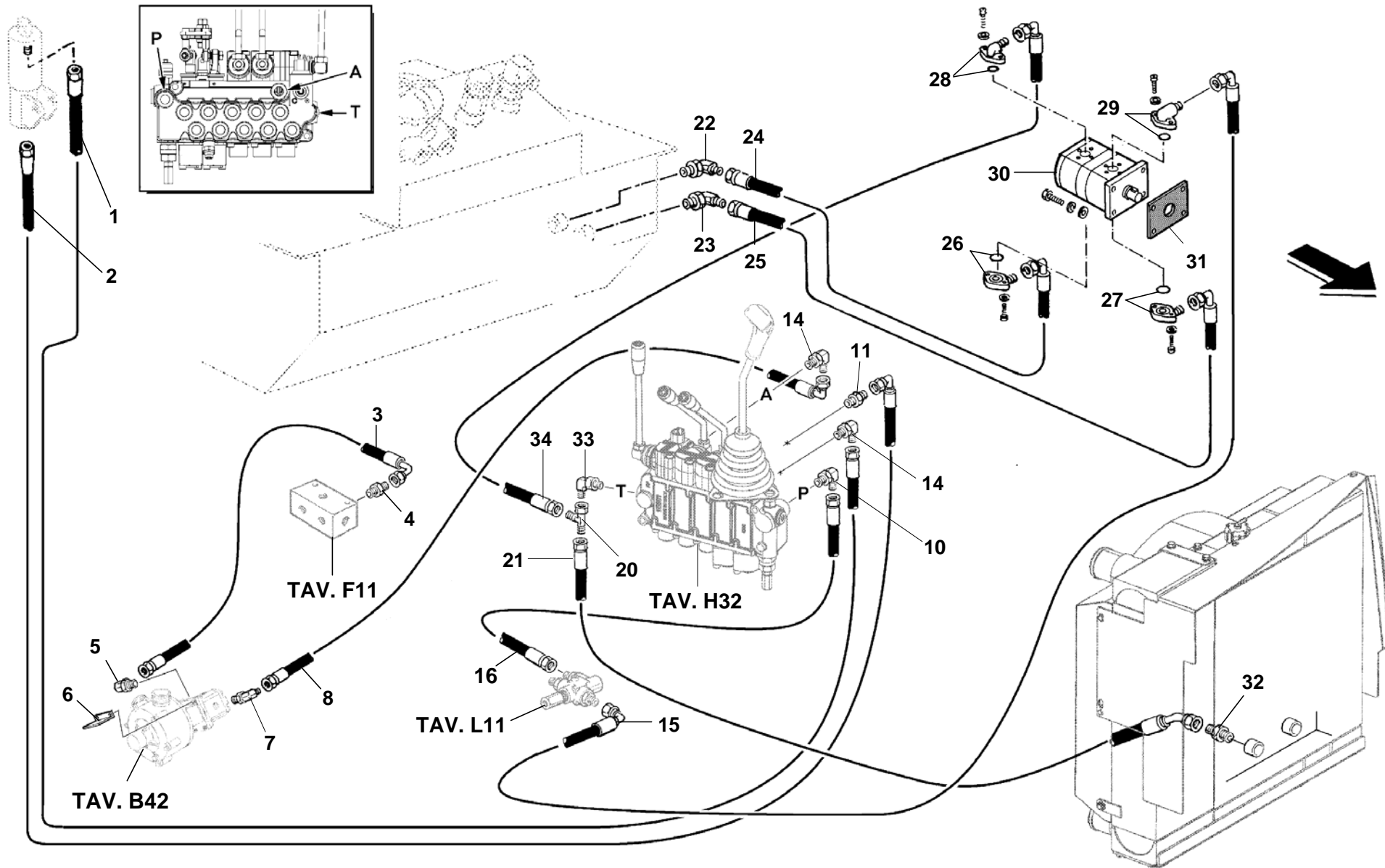

Tav. **H33 13**
Tab.

Validità da matricola / a matricola: **BF08HB1354** /
PIN Nr. from / to :

COD.ORDINE: **445H3313XX**
S/P ORDER :

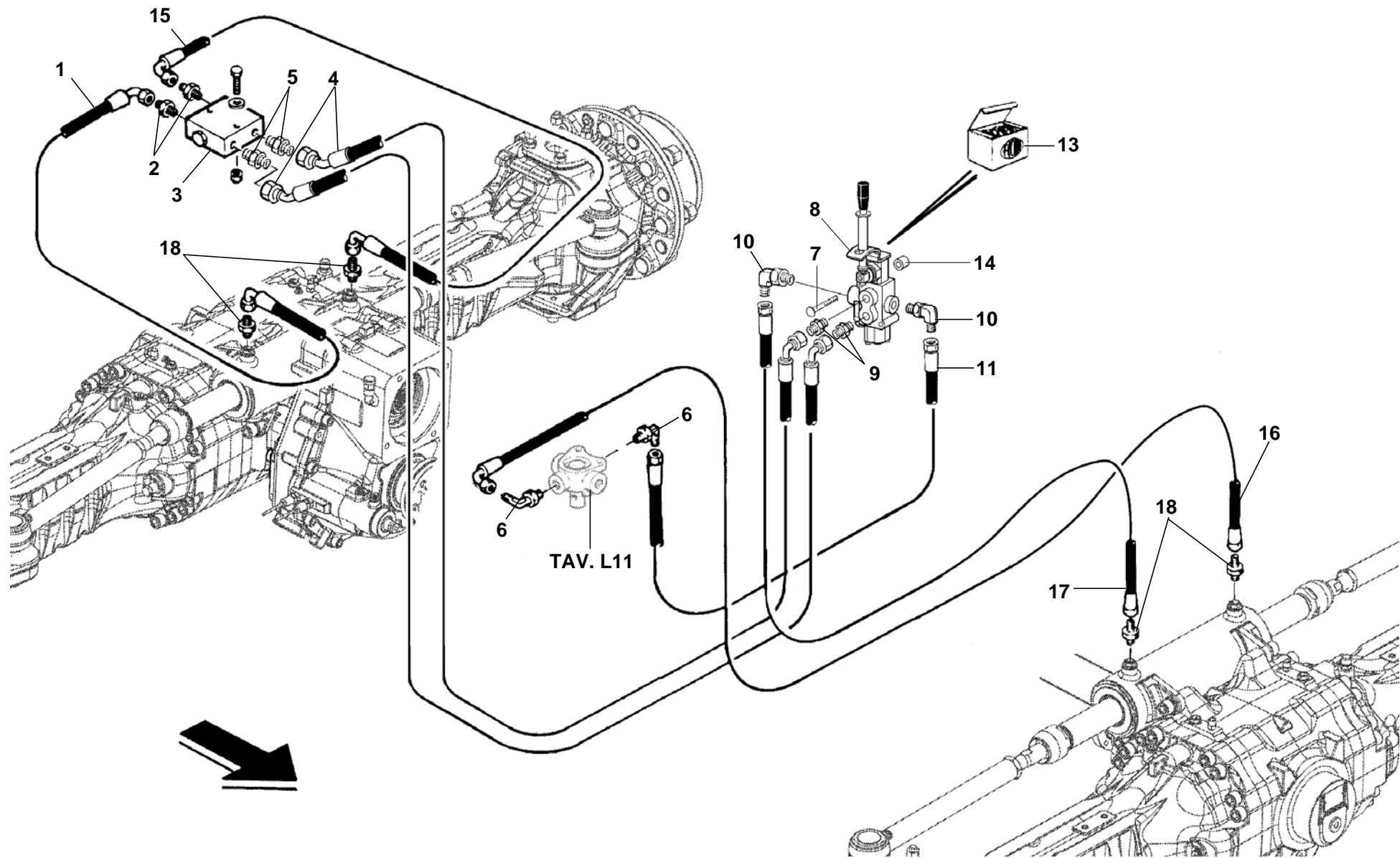

Tav. **L10 05**
 Tab.

Validità da matricola / a matricola: **BF08HB1222** /
 PIN Nr. from / to :

COD.ORDINE: **445L1005XX**
 S/P ORDER :

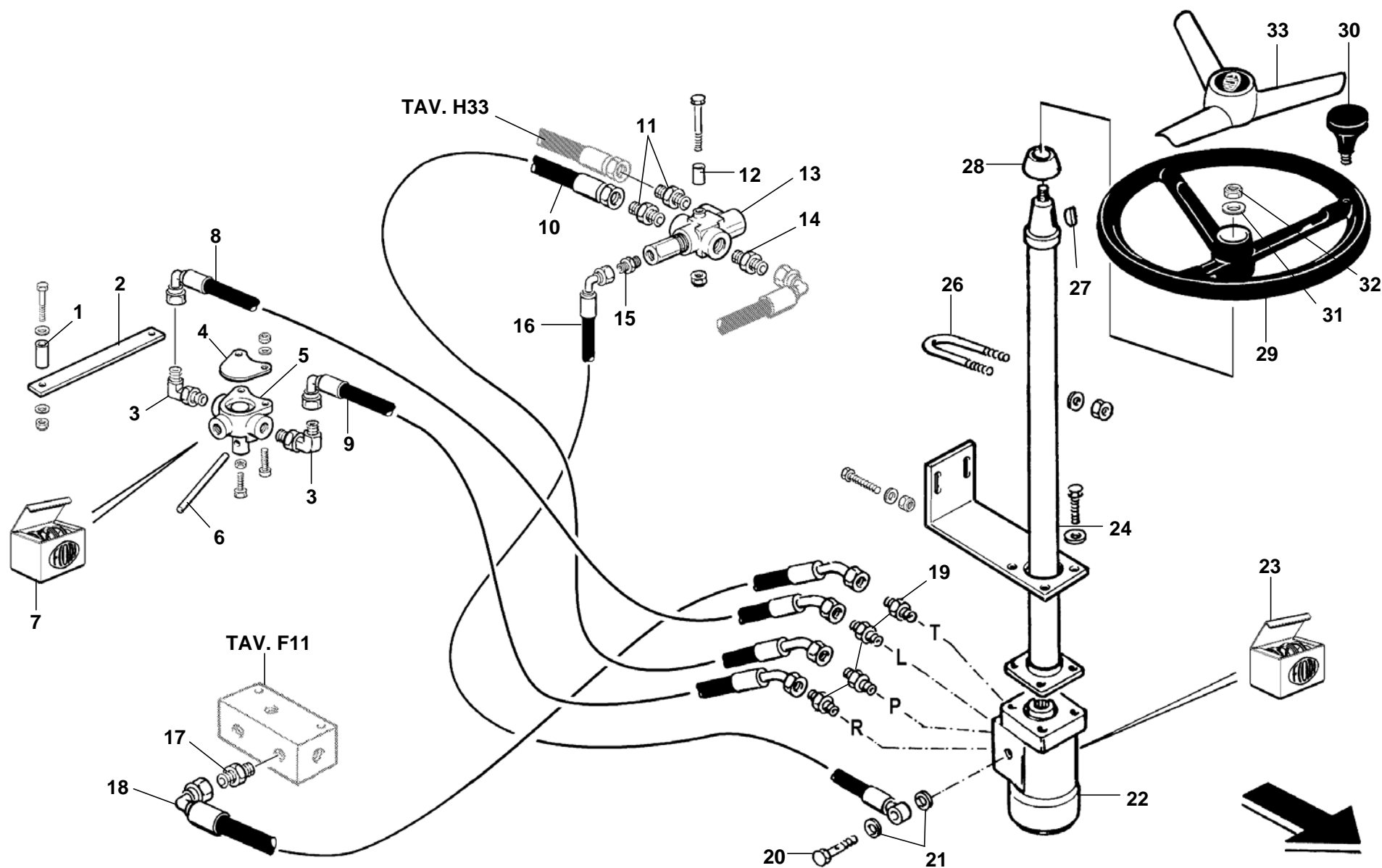

Tav. **L11 03**
Tab.

Validità da matricola / a matricola: **BF08HB1078** /
PIN Nr. from / to :

COD.ORDINE: **445L1103XX**
S/P ORDER :

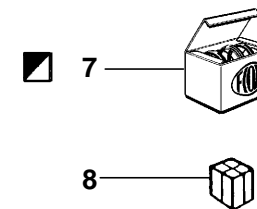
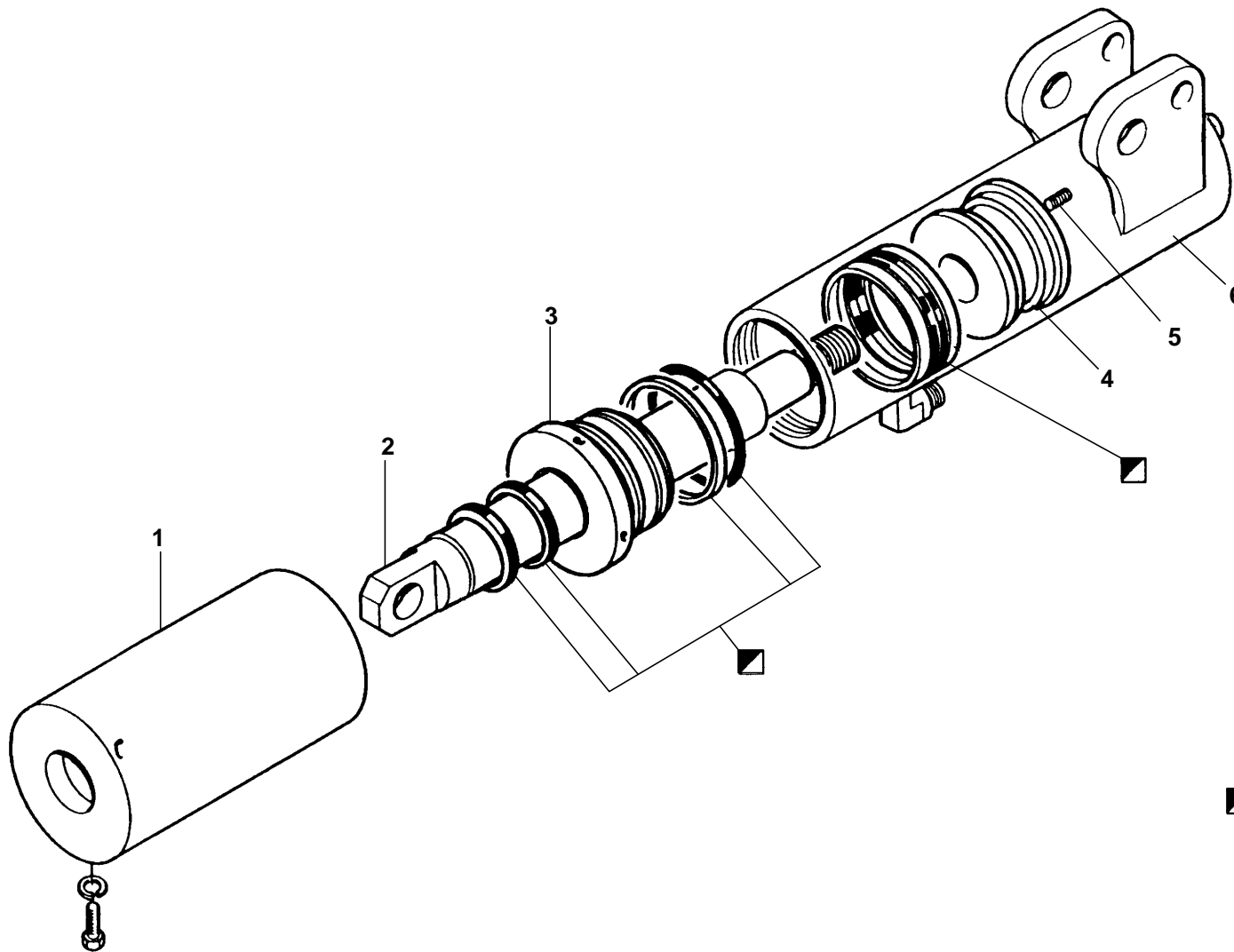

Tav. **M05 01**
 Tab.

Validità da matricola / a matricola: **BF08HB1078** /
 PIN Nr. from / to :

COD.ORDINE: **445M0501XX**
 S/P ORDER :

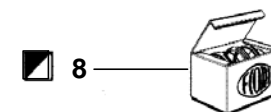
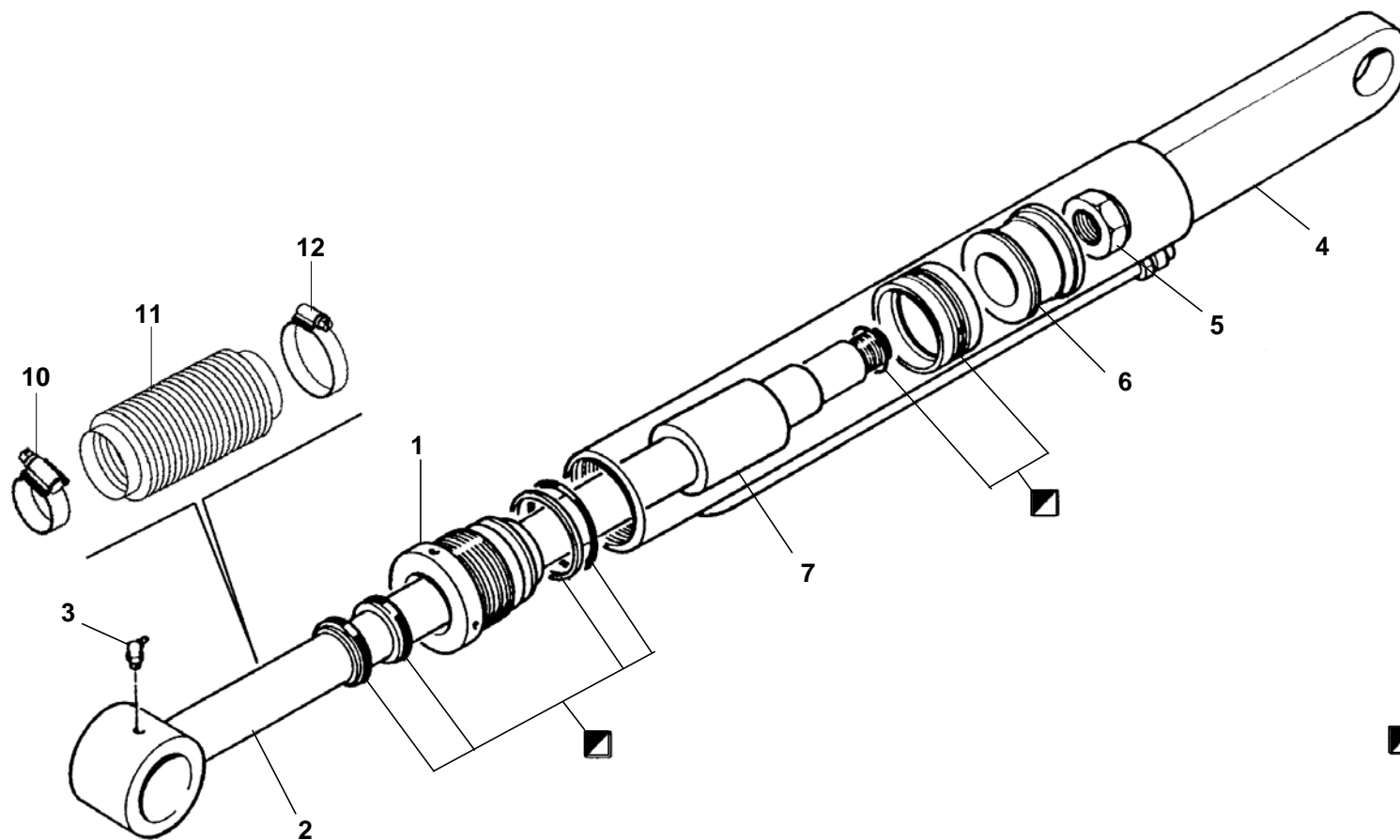

8

9



Tav. **M08 02**
Tab.

Validità da matricola / a matricola: **BF08HB1078** /
PIN Nr. from / to :

COD.ORDINE: **445M0802XX**
S/P ORDER :

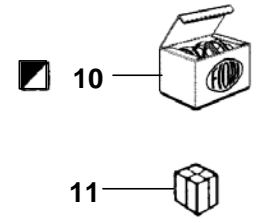
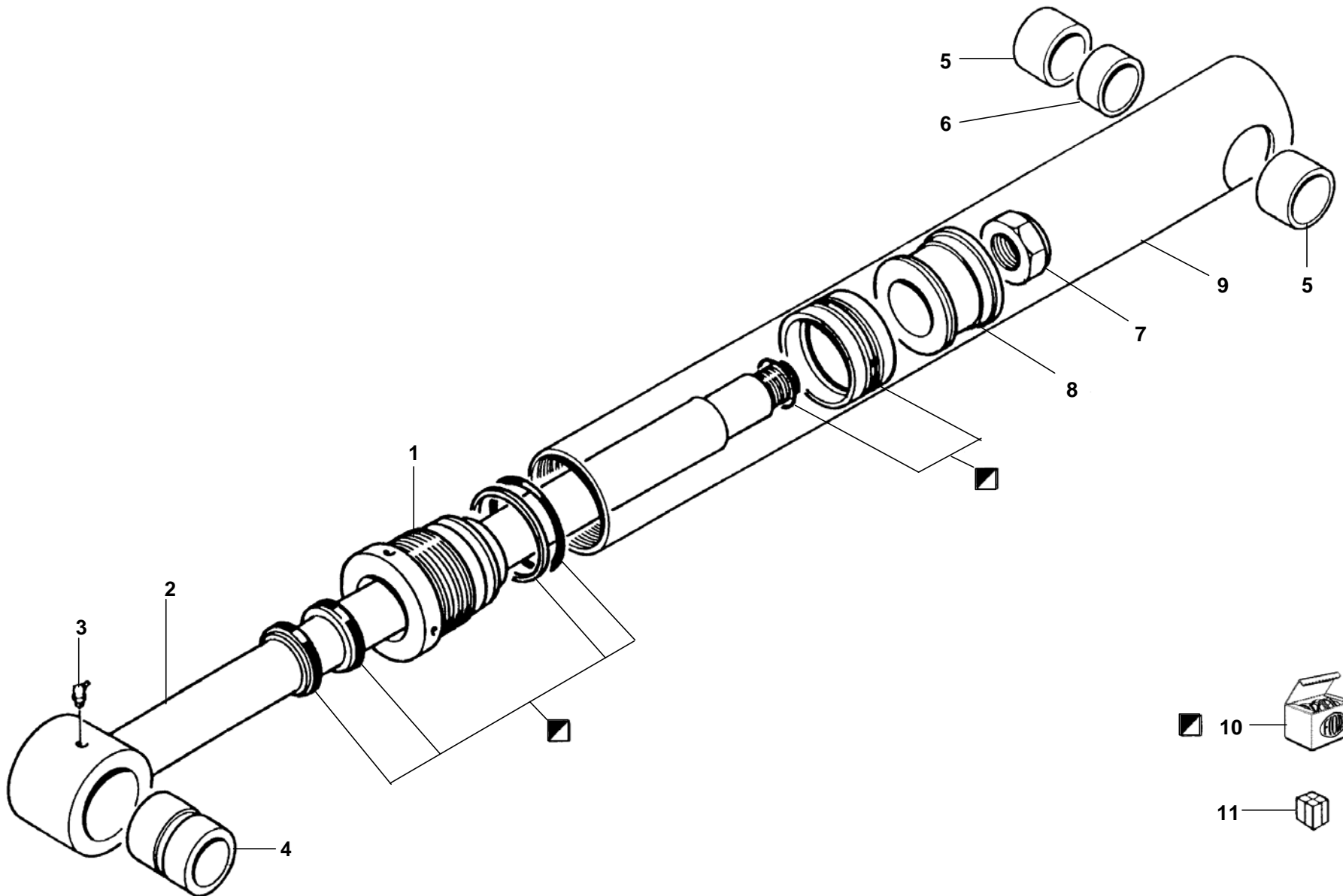

Tav. **M09 01**
 Tab.

Validità da matricola / a matricola: **BF08HB1354 /**
 PIN Nr. from / to :

COD.ORDINE: **445M0901XX**
 S/P ORDER :

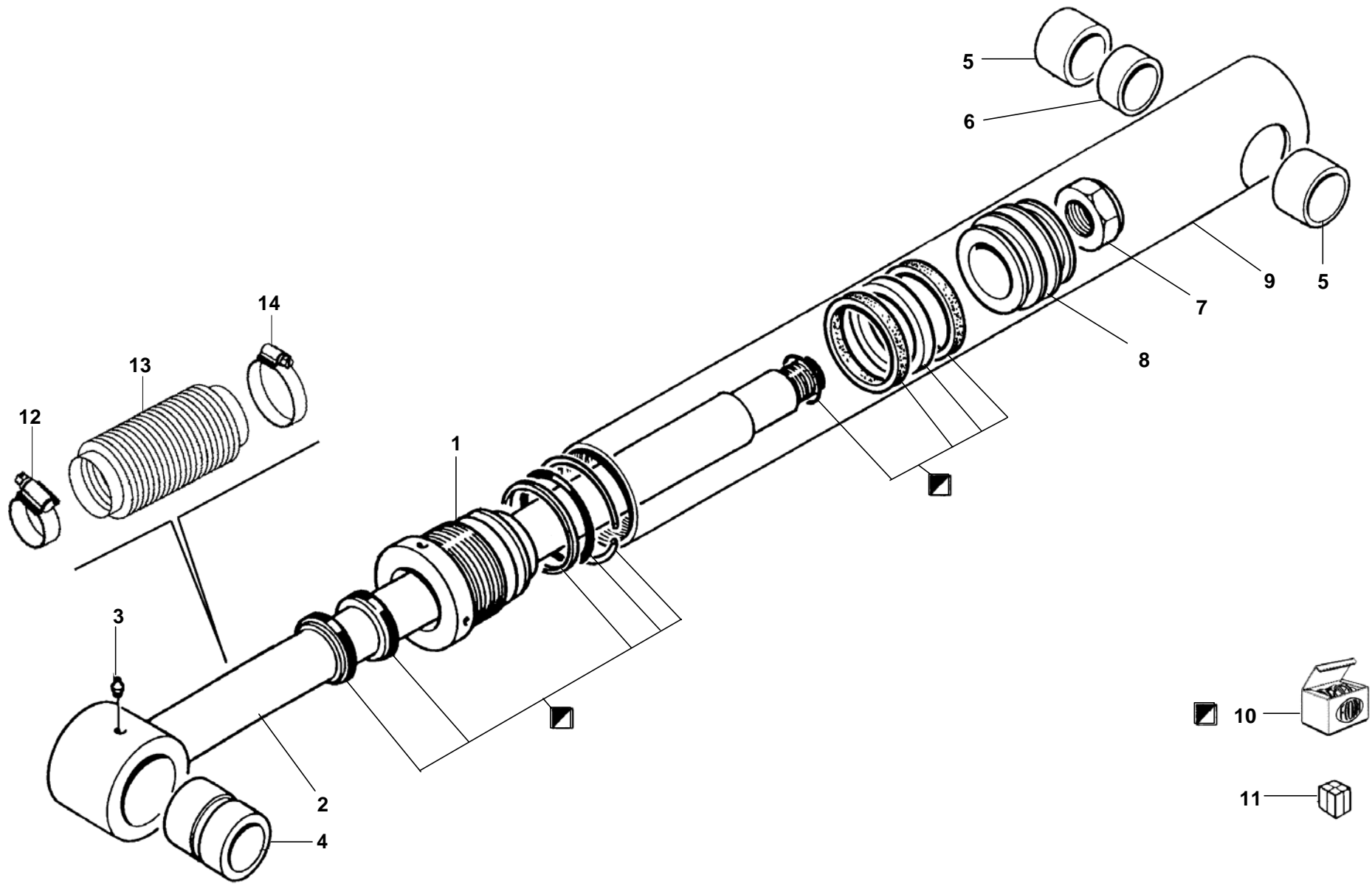

Tav. **M10 02**
 Tab.

Validità da matricola / a matricola: **BF08HB1078** /
 PIN Nr. from / to :

COD.ORDINE: **445M1002XX**
 S/P ORDER :

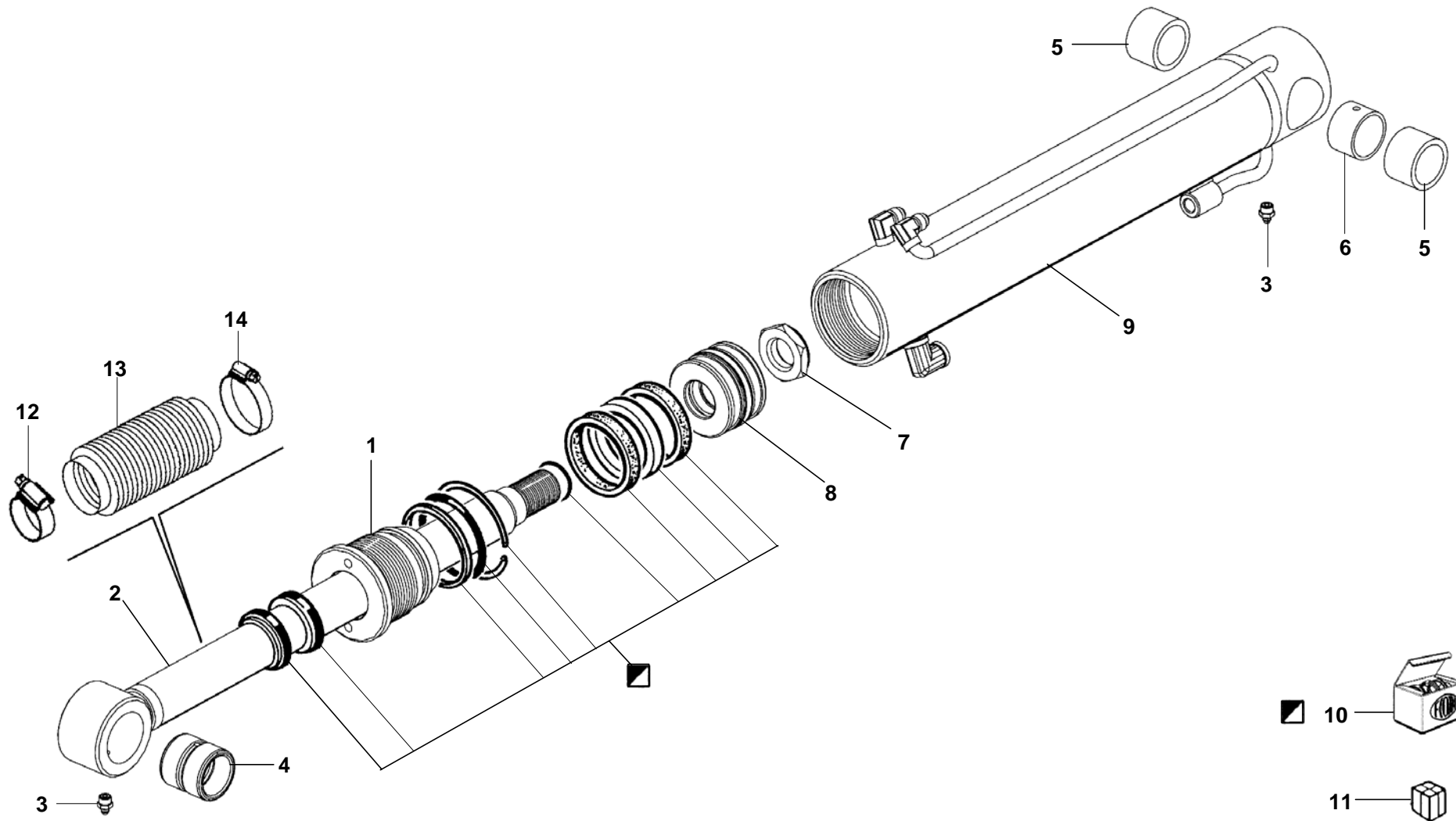

Tav. **M23 00**
 Tab.

Validità da matricola / a matricola: **BF08HB1078** /
 PIN Nr. from / to :

COD.ORDINE: **445M2300XX**
 S/P ORDER :

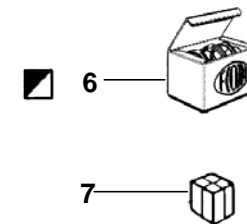
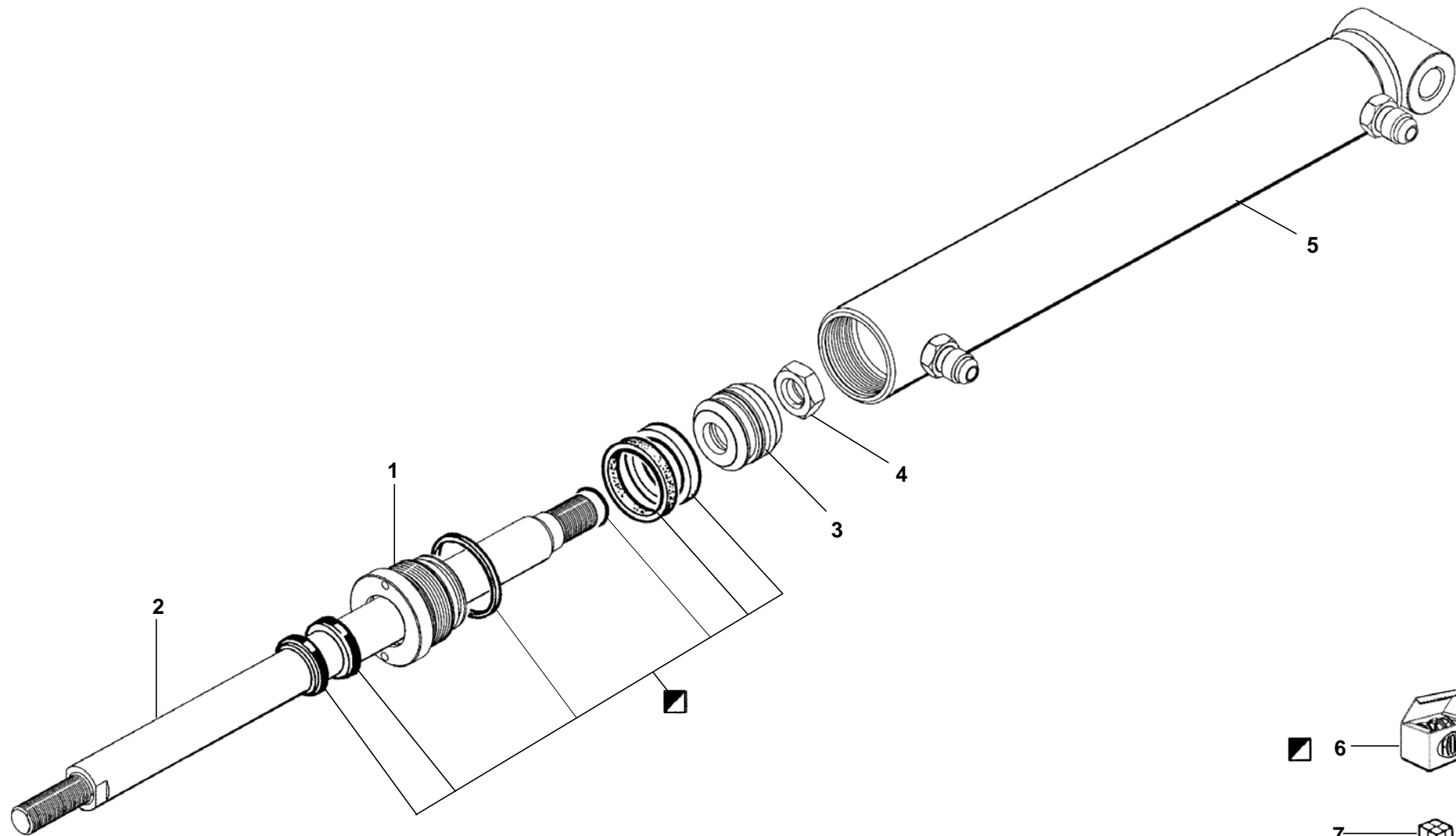

Tav. **M25 00**
Tab.

Validità da matricola / a matricola: **BF08HB0900** /
PIN Nr. from / to :

COD.ORDINE: **445M2500XX**
S/P ORDER :

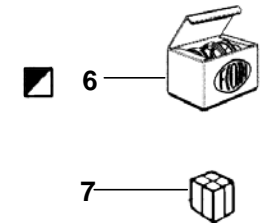
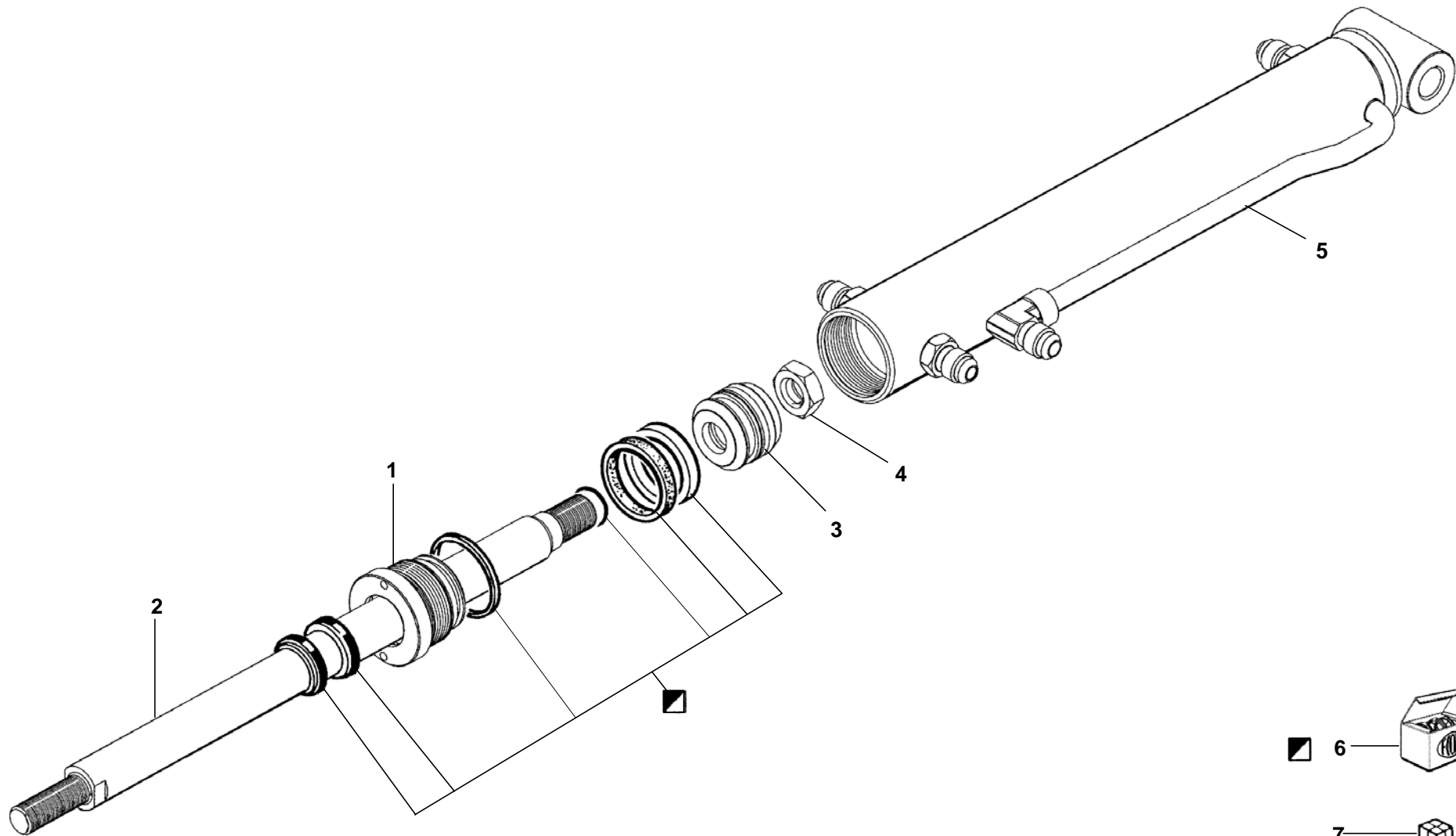

Tav. **M26 00**
 Tab.

Validità da matricola / a matricola: **BF08HB0900** /
 PIN Nr. from / to :

COD.ORDINE: **445M2600XX**
 S/P ORDER :

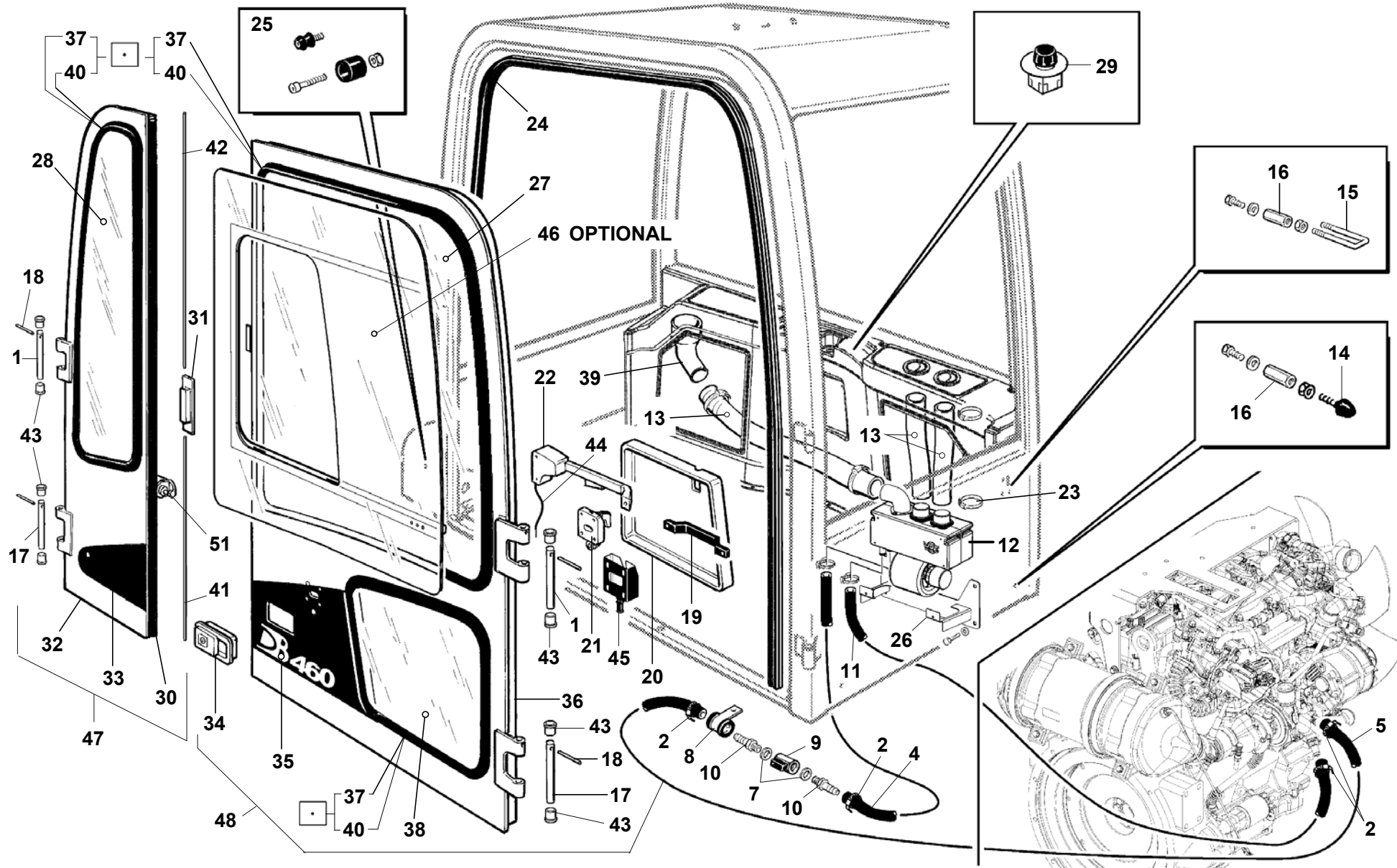

Tav. **P11 02**
 Tab.

Validità da matricola / a matricola: **BF08HB1078** /
 PIN Nr. from / to :

COD.ORDINE: **445P1102XX**
 S/P ORDER :

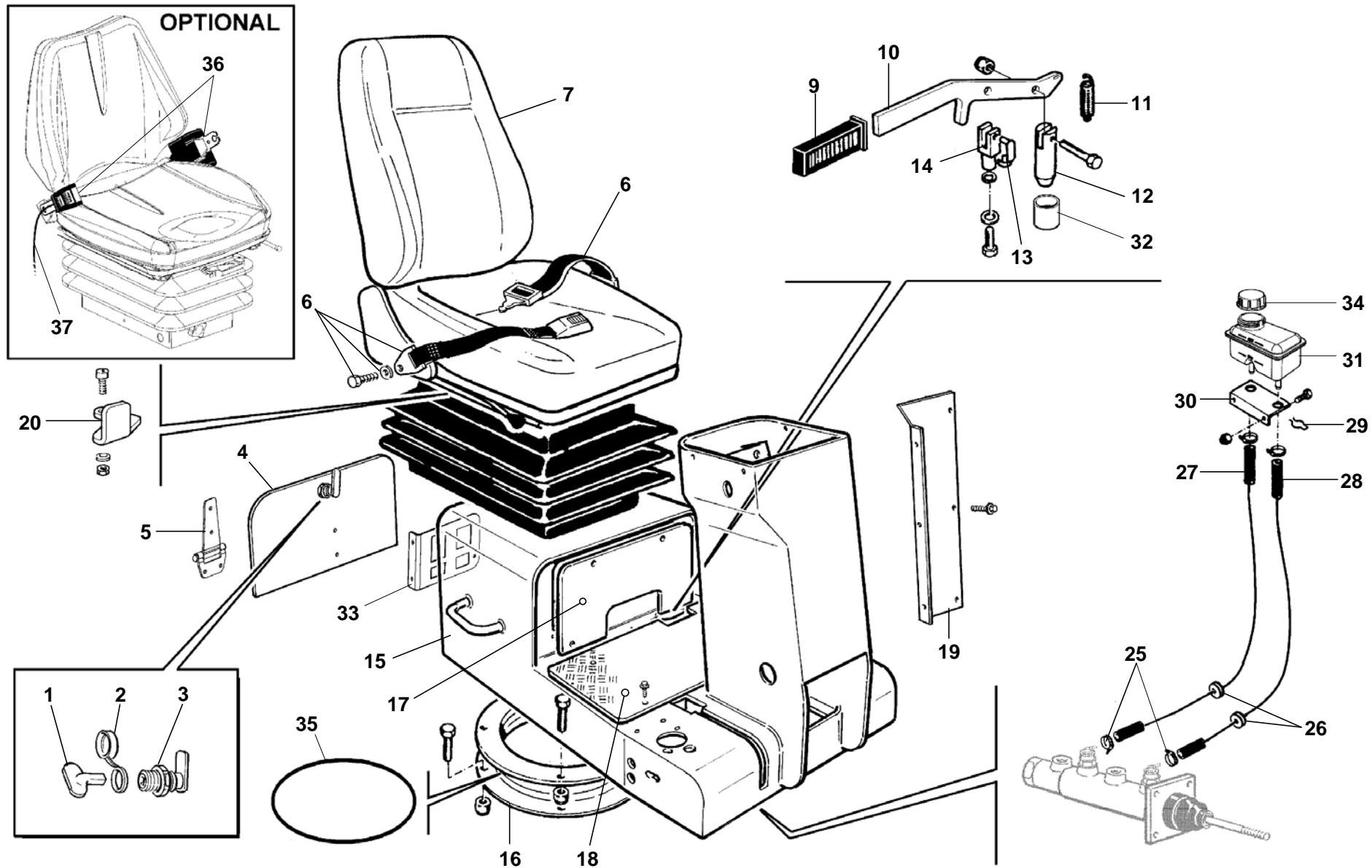

Tav. **P12 09**
Tab.

Validità da matricola / a matricola: **BF08HB1425** /
PIN Nr. from / to :

COD.ORDINE: **445P1209XX**
S/P ORDER :

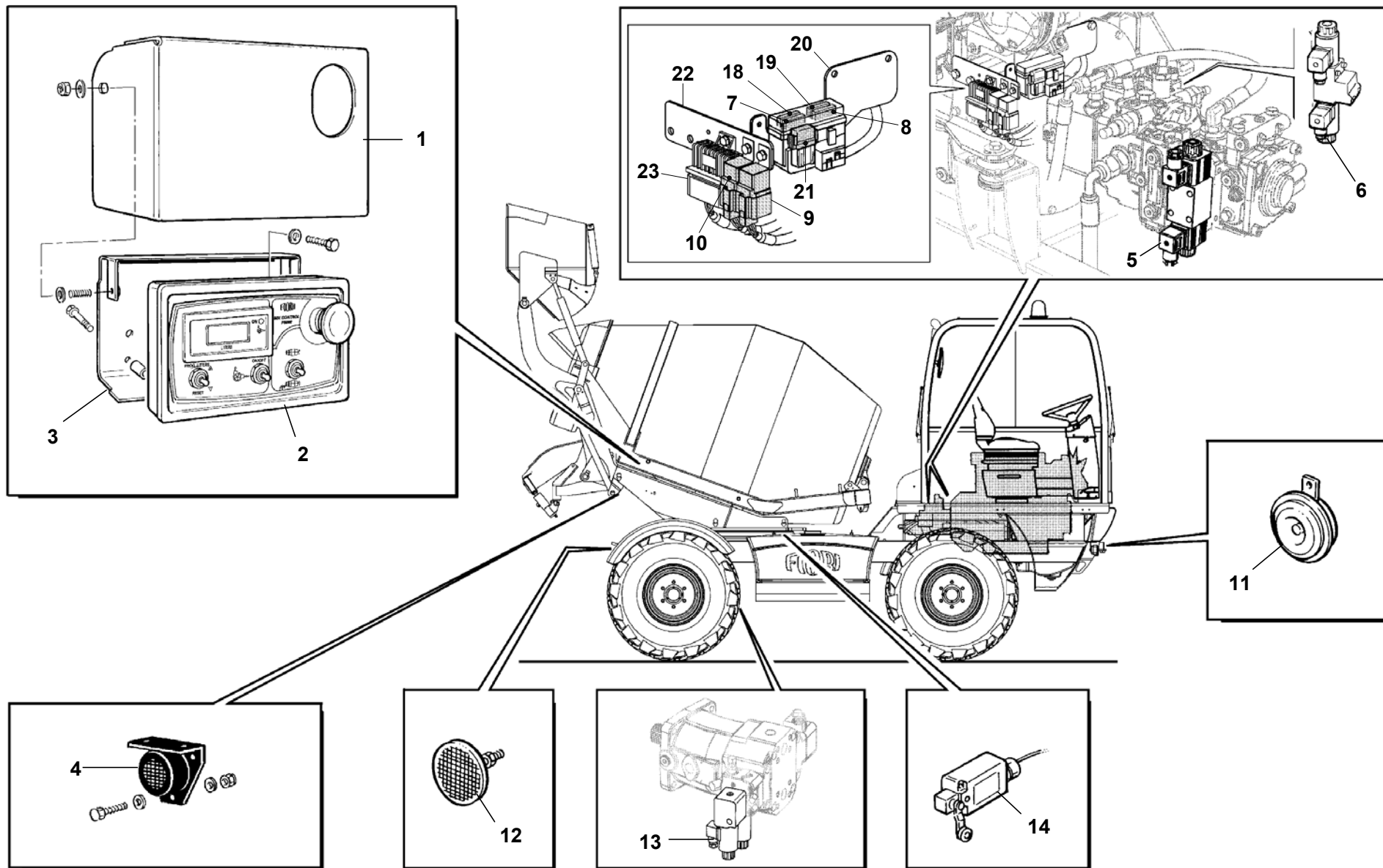

Tav. **V11 10**
 Tab.

Validità da matricola / a matricola: **BF08HB1532 /**
 PIN Nr. from / to :

COD.ORDINE: **445V1110XX**
 S/P ORDER :

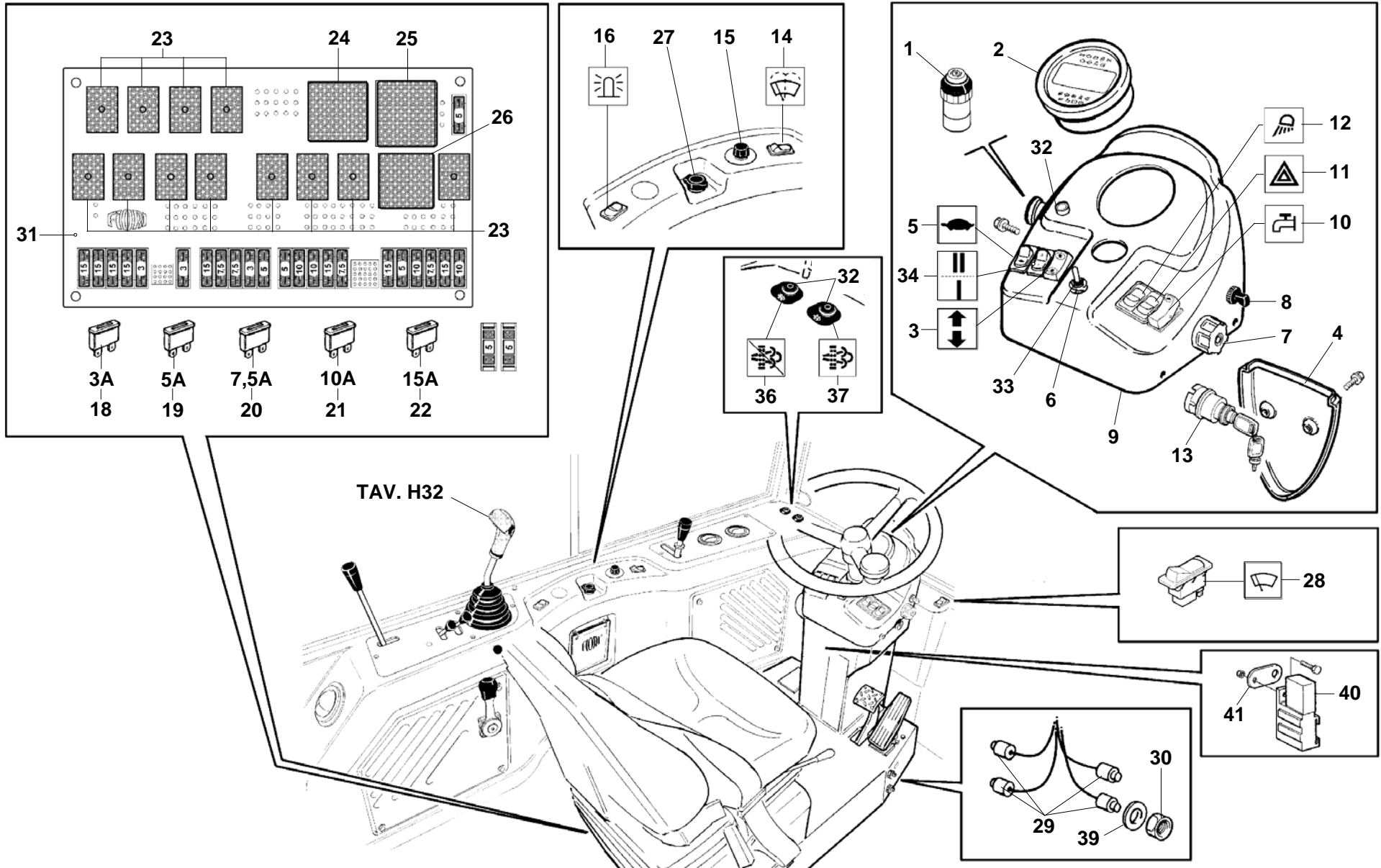

Tav. V12 21
Tab.

Validità da matricola / a matricola: BF08HB1417 /
PIN Nr. from / to :

COD.ORDINE: 445V1221XX
S/P ORDER :

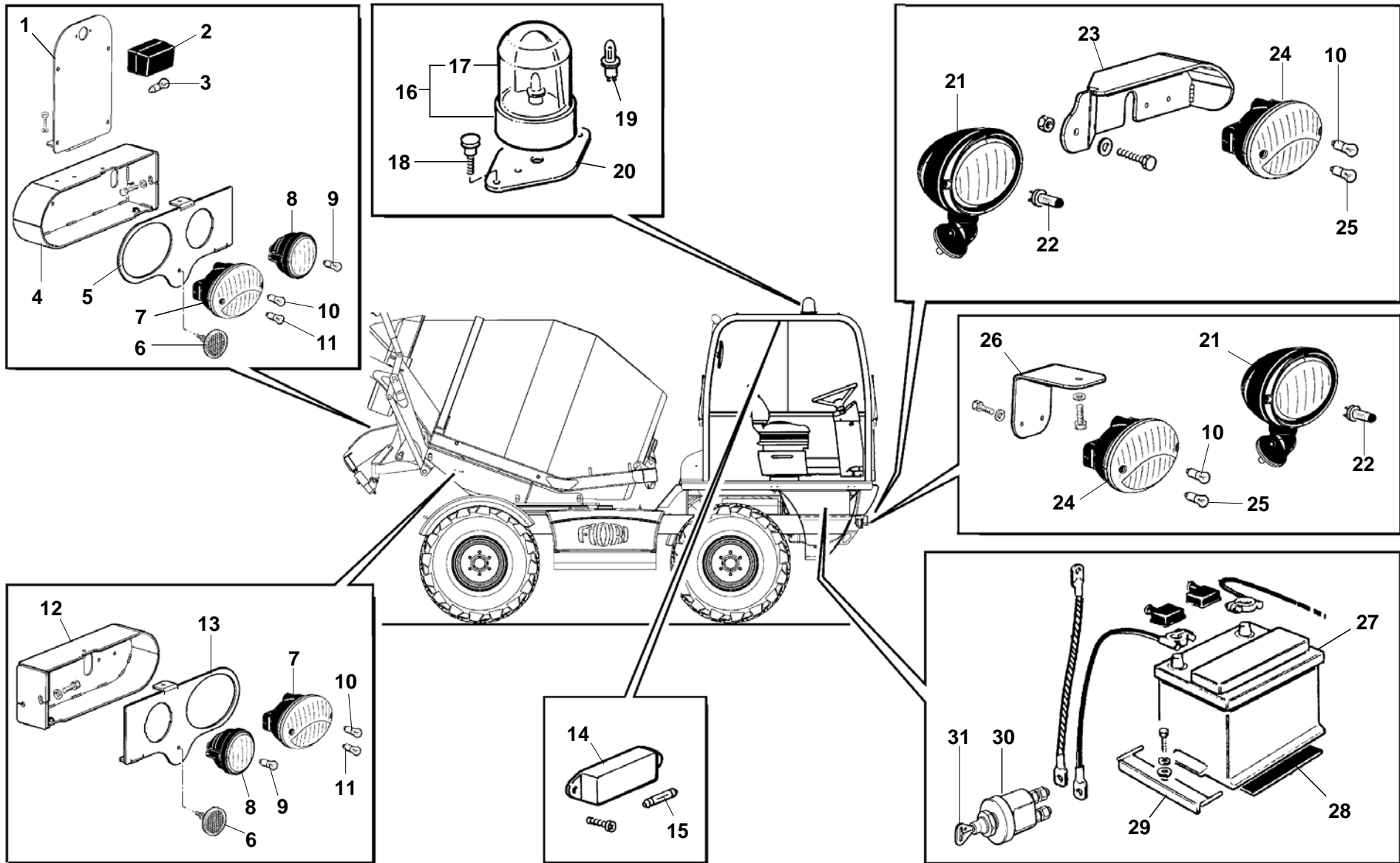

Tav. **V13 04**
Tab.

Validità da matricola / a matricola: **BF08HB1417** /
PIN Nr. from / to :

COD.ORDINE: **445V1304XX**
S/P ORDER :

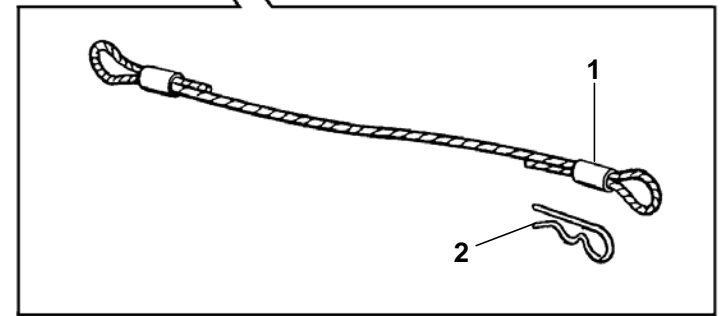
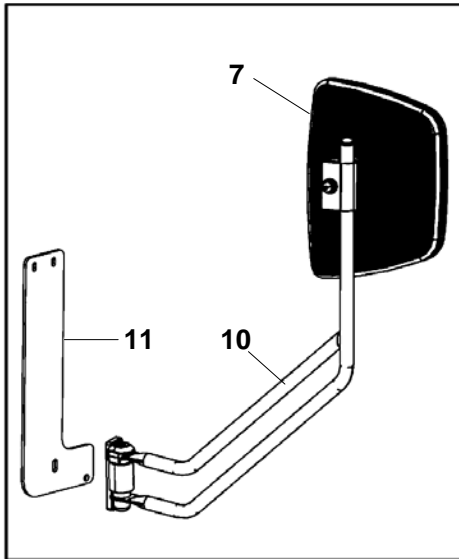
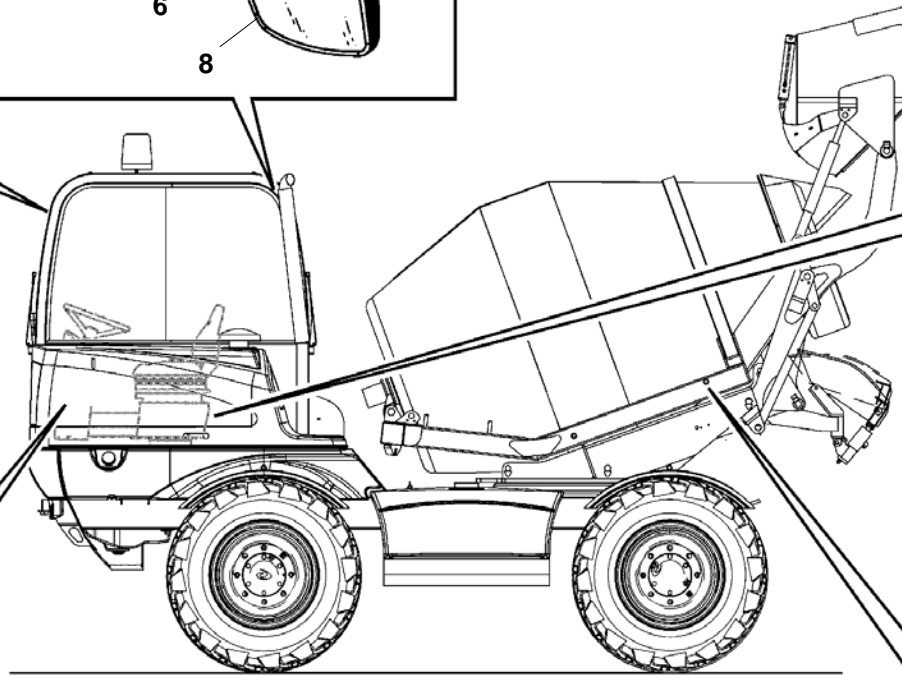
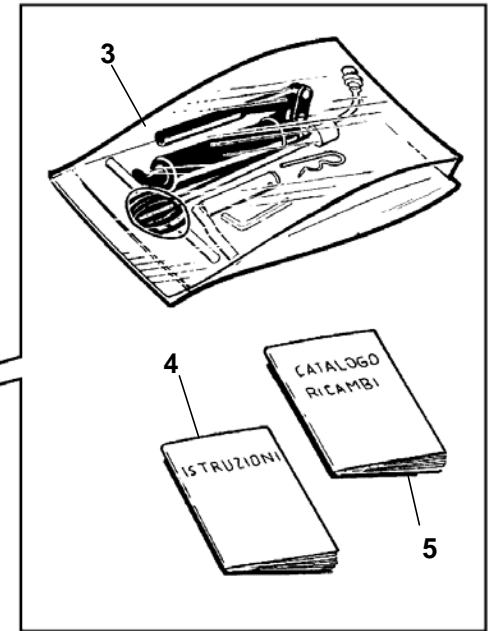
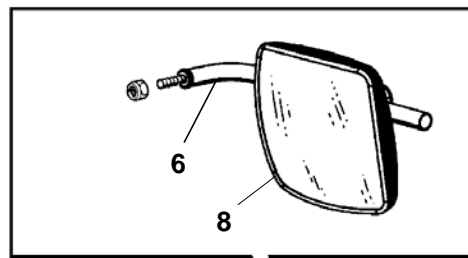
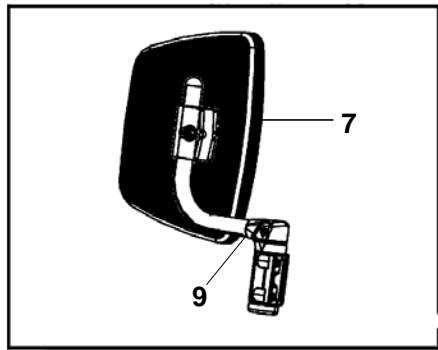

Tav. **Z16 10**
Tab.

Validità da matricola / a matricola: **BF08HB1350** /
PIN Nr. from / to :

COD.ORDINE: **445Z1610XX**
S/P ORDER :

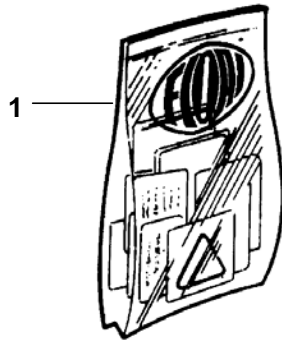

2

FIORI	FIORI GROUP S.p.A. Finale Emilia (Modena) Italy
TYPE:	MACHINE: SELF LOADING MOBILE MIXER
SERIAL NUMBER:	
OPERATING MASS:	— kg
ENGINE POWER:	
CE	MANUFACTURE YEAR _____
	315503

3

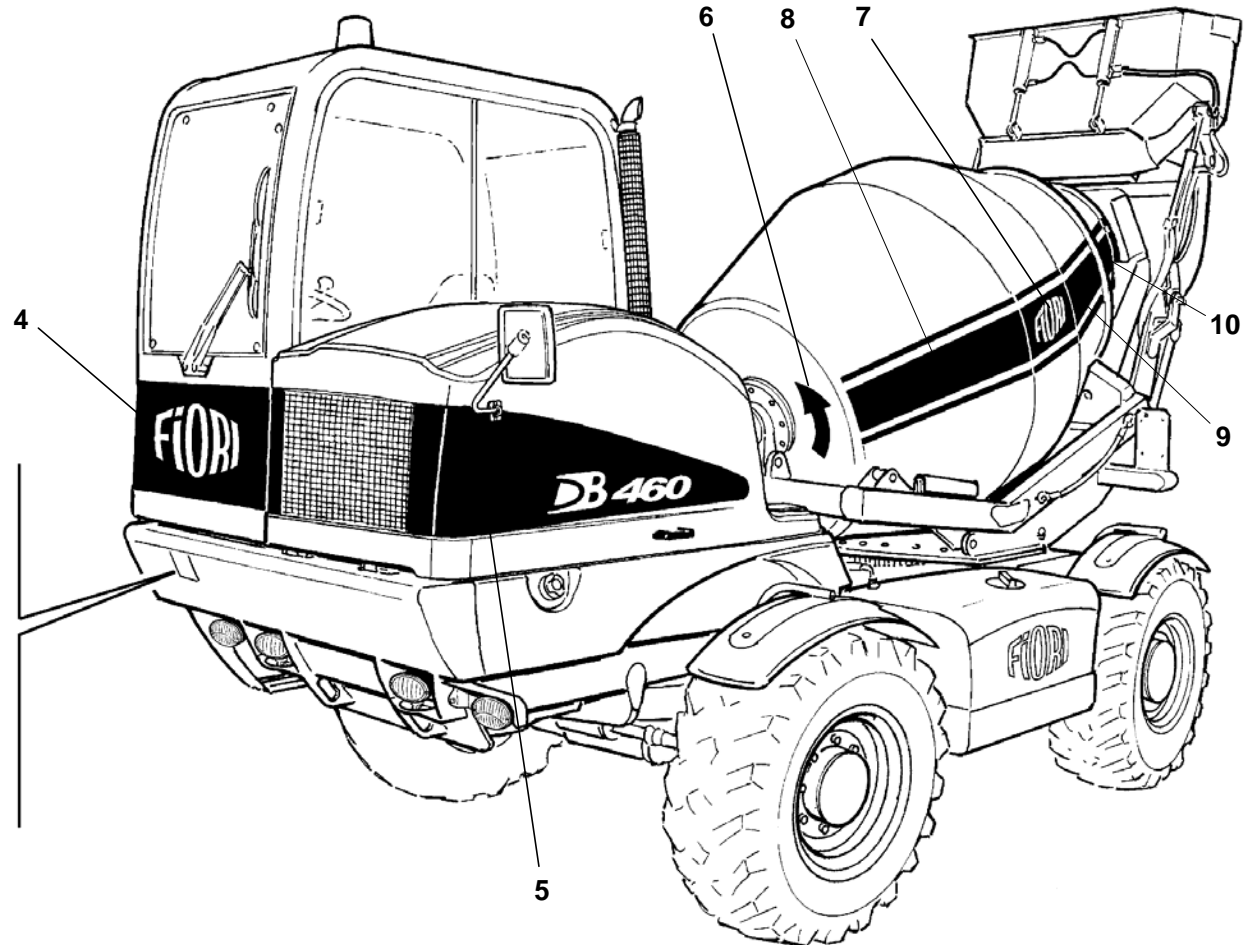

Tav. **Z23 10**
Tab.

Validità da matricola / a matricola: **BF08HB1078** /
PIN Nr. from / to :

COD.ORDINE: **445Z2309XX**
S/P ORDER :

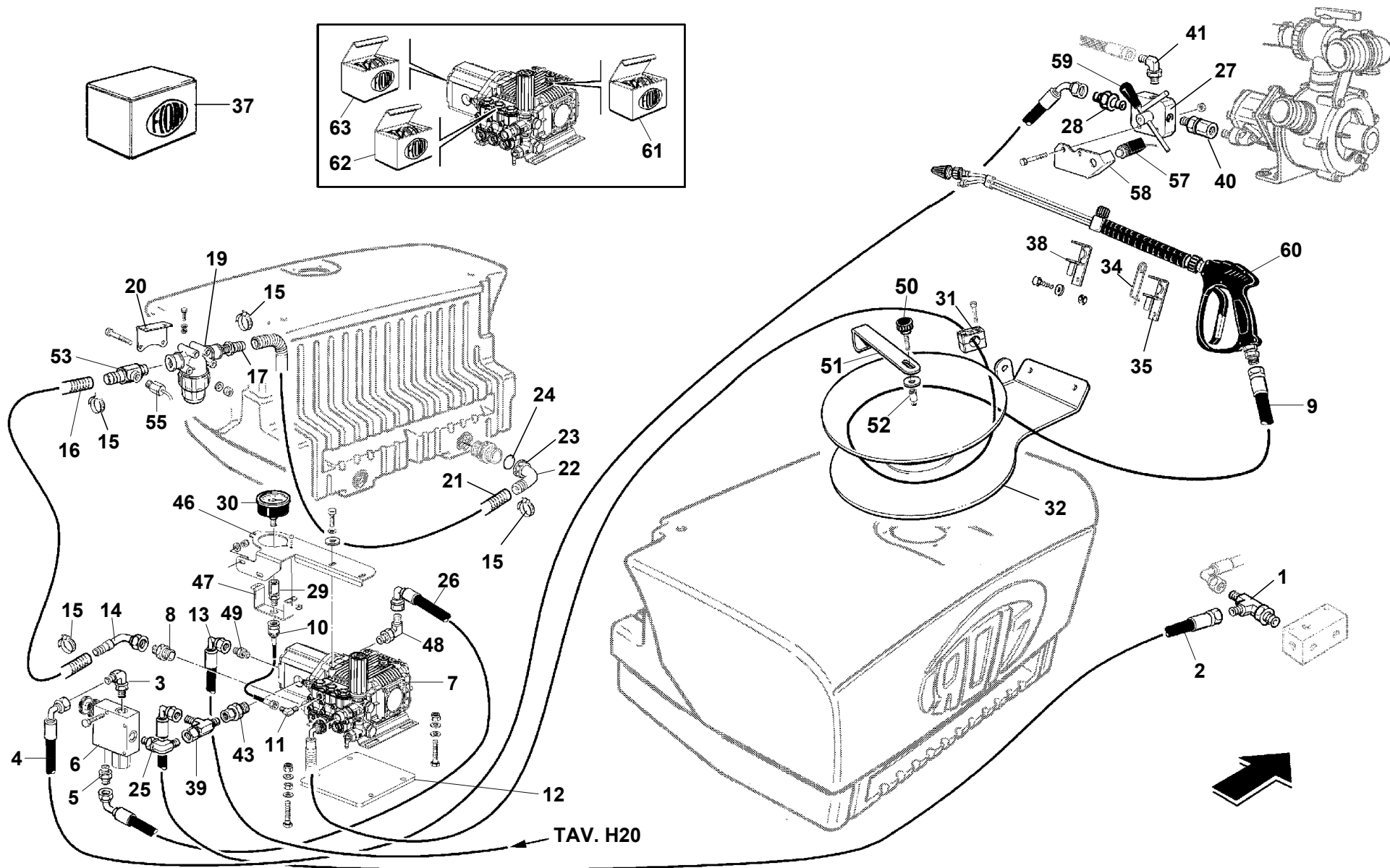

Tav.
Tab. **Z31 10**

Validità da matricola / a matricola: **BF08HB1510** /
PIN Nr. from / to :

COD.ORDINE:
S/P ORDER : **445Z3110XX**

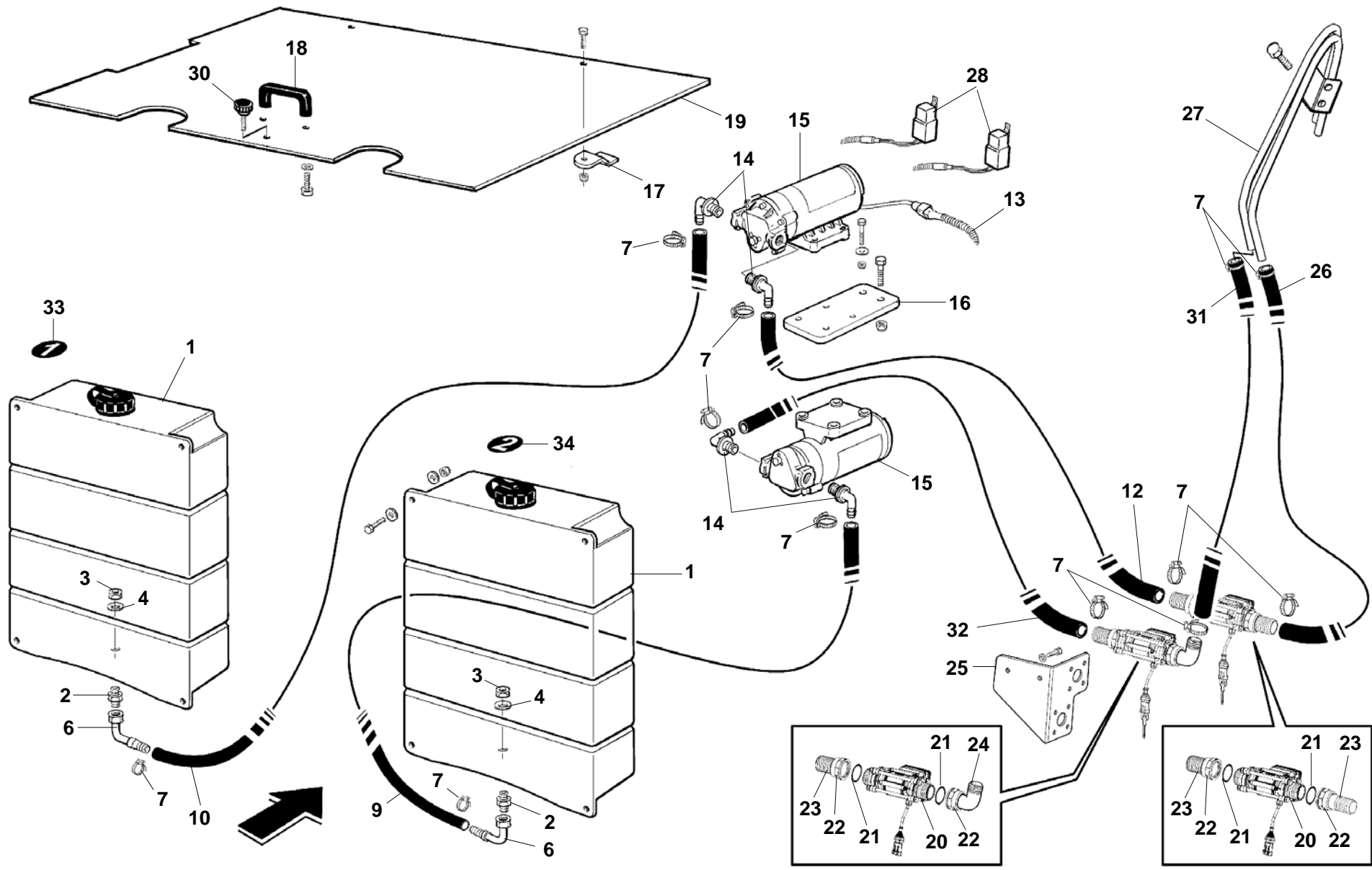

Tav. **Z42 12**
 Tab.

Validità da matricola / a matricola: **BF08HB1377** /
 PIN Nr. from / to :

COD.ORDINE: **445Z4212XX**
 S/P ORDER :

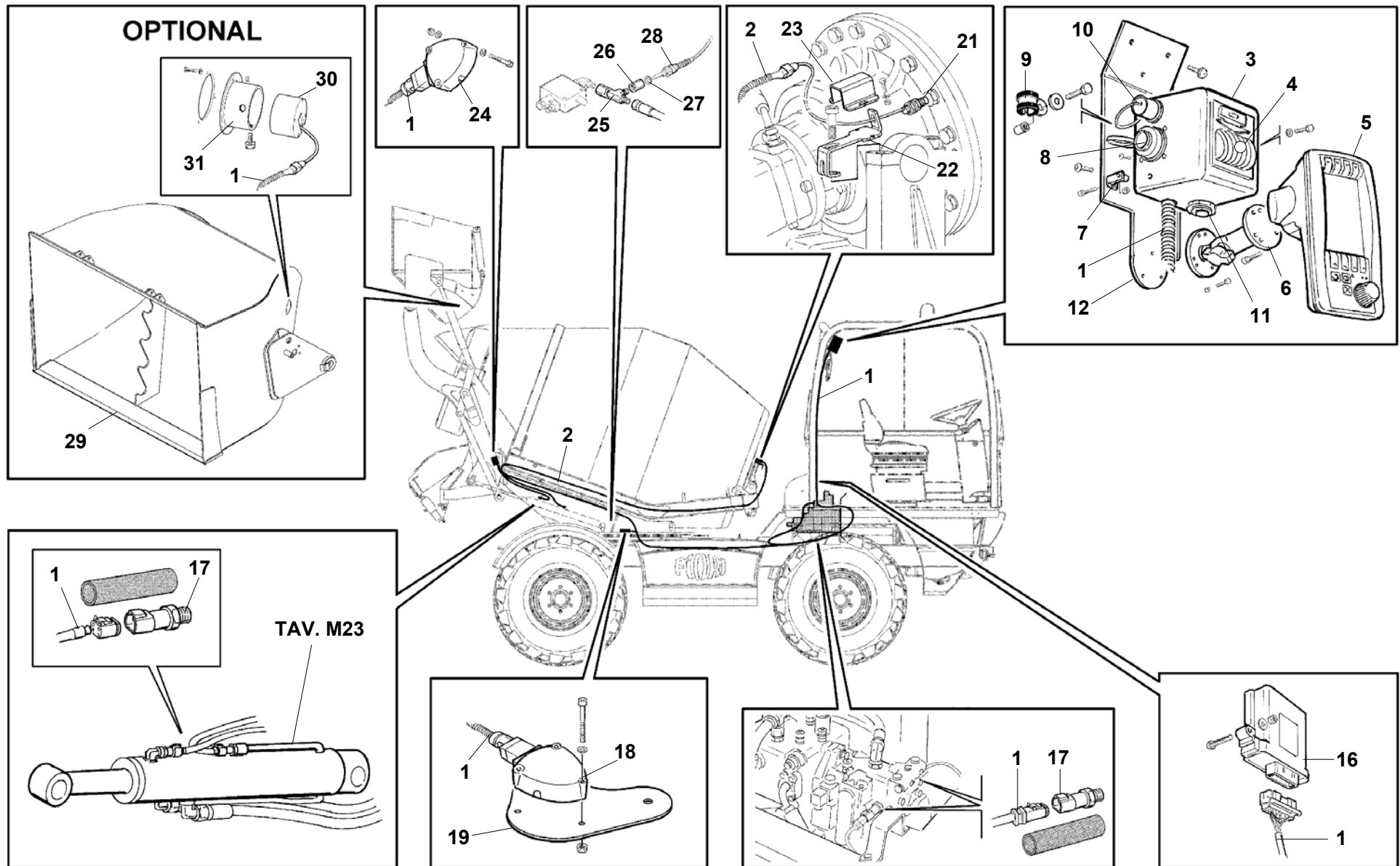

Tav. **Z42 14 CBV 2.0**
 Tab.

Validità da matricola / a matricola: **BF08HB1520** /
 PIN Nr. from / to :

COD.ORDINE: **445Z4214XX**
 S/P ORDER :

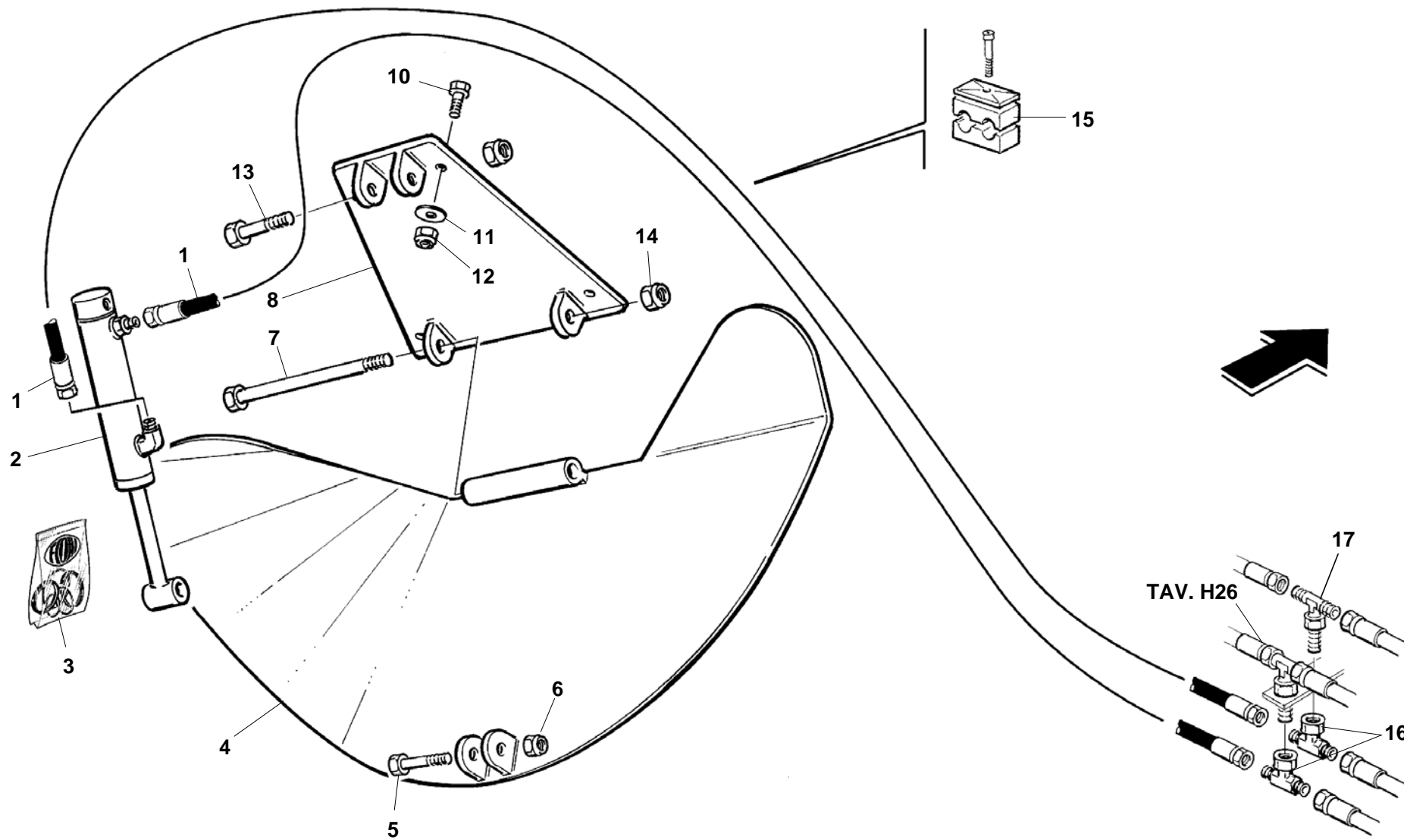

Tav. **Z44 02**
 Tab.

Validità da matricola / a matricola: **BF08HB1078** /
 PIN Nr. from / to :

COD.ORDINE: **444Z4402XX**
 S/P ORDER :

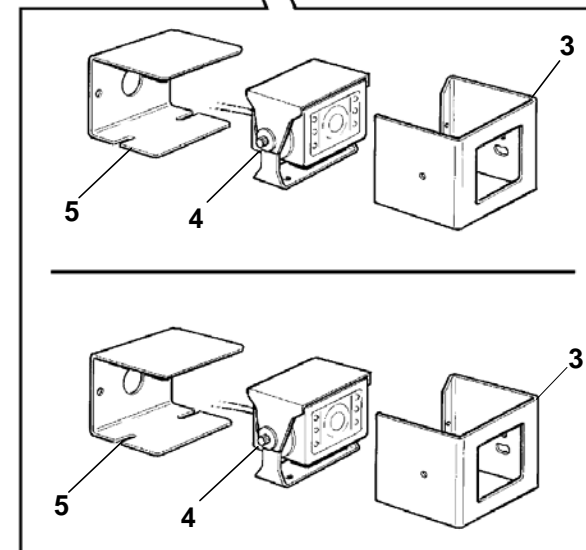
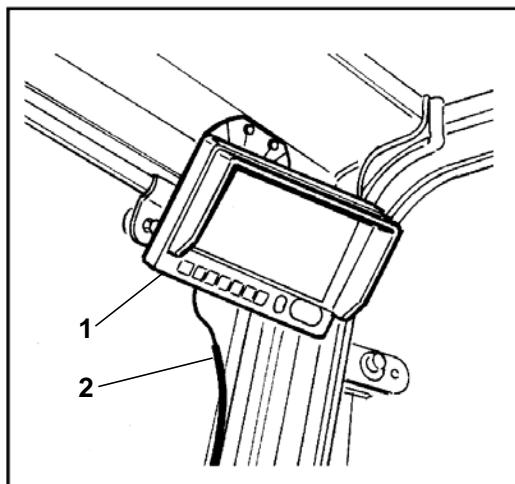
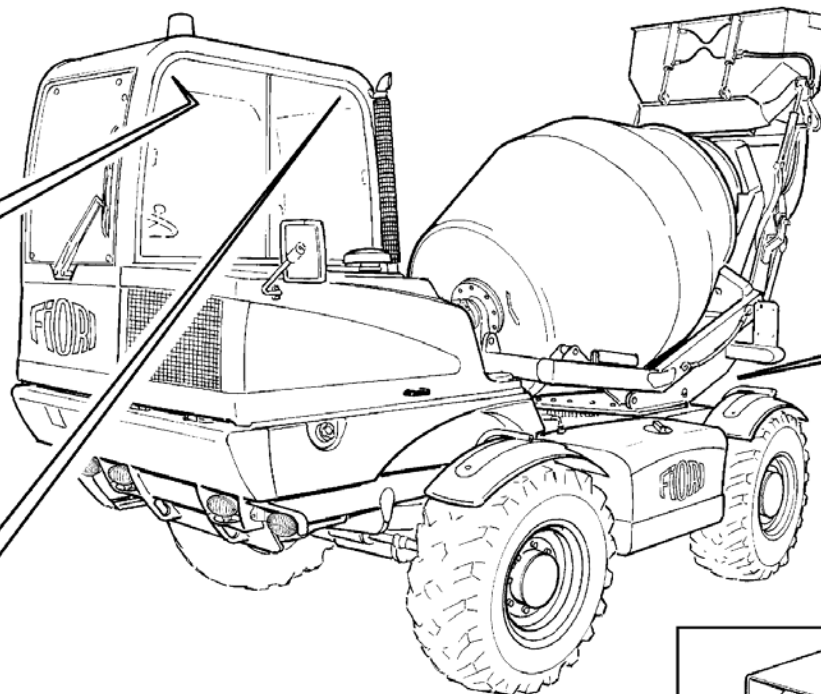
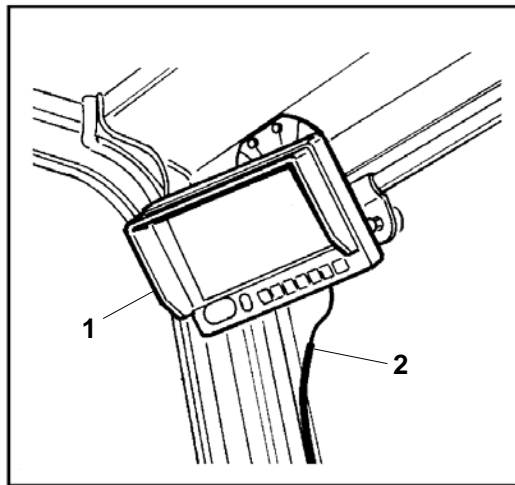

Tav. **Z60 03**
Tab.

Validità da matricola / a matricola: **BF08HB1350** /
PIN Nr. from / to :

COD.ORDINE: **444Z6003XX**
S/P ORDER :

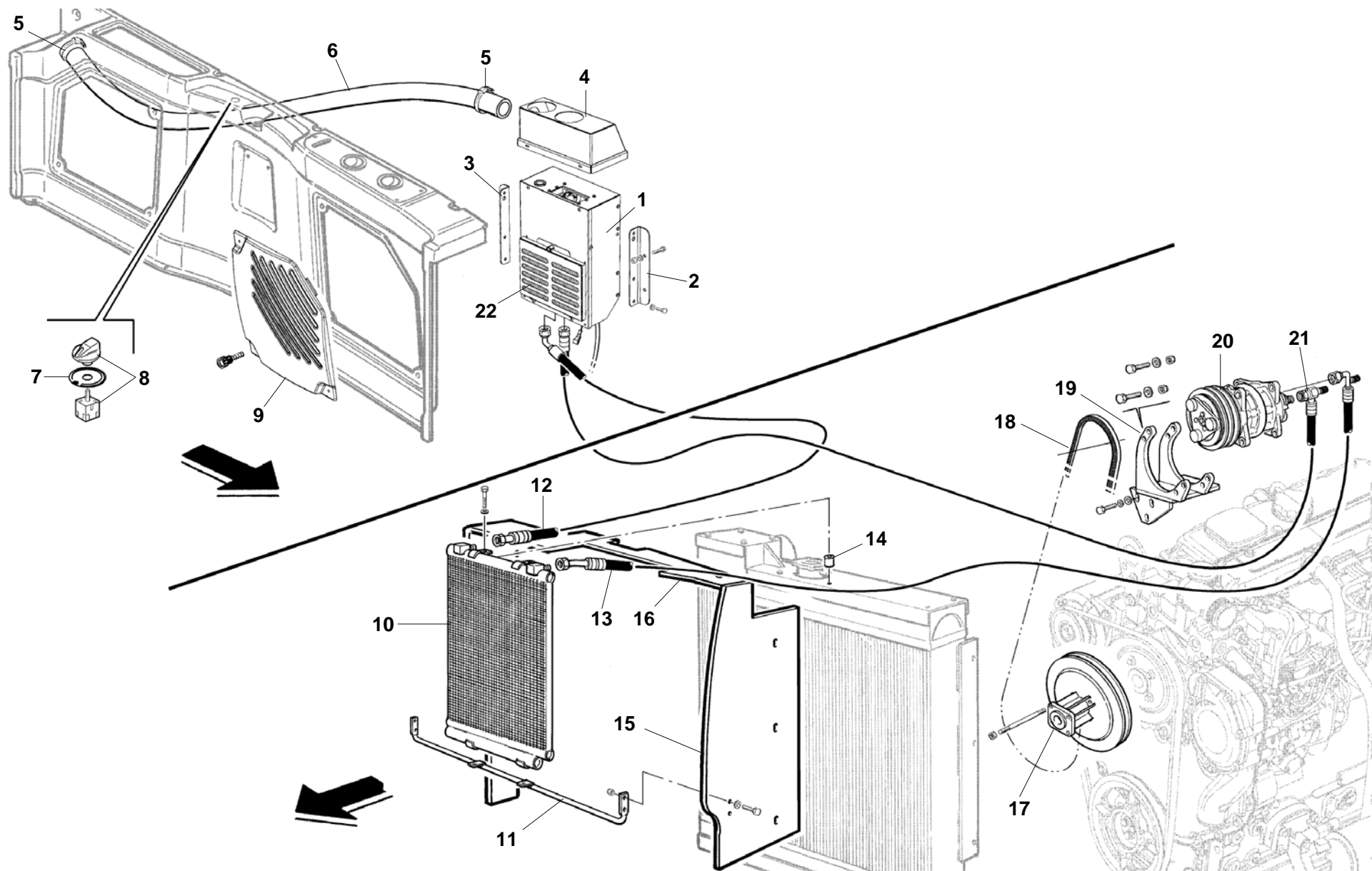

Tav.
Tab. **Z67 01**

Validità da matricola / a matricola: **BF08HB1078** /
PIN Nr. from / to :

COD.ORDINE:
S/P ORDER : **445Z6701XX**

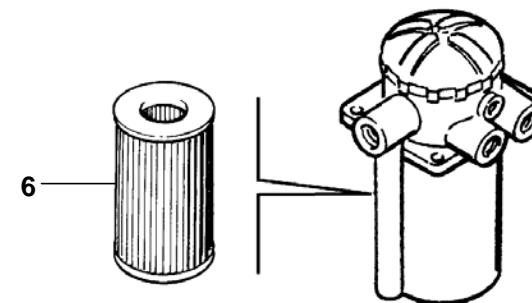
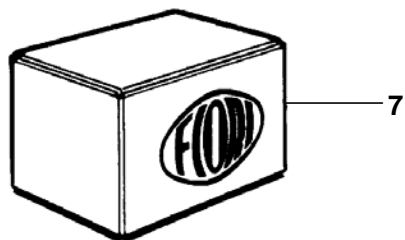
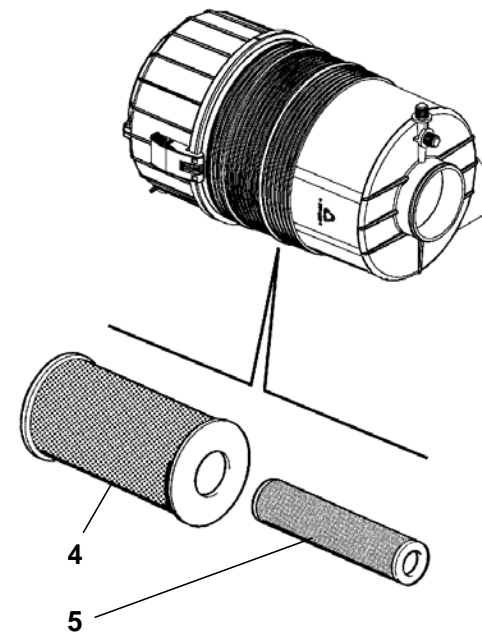
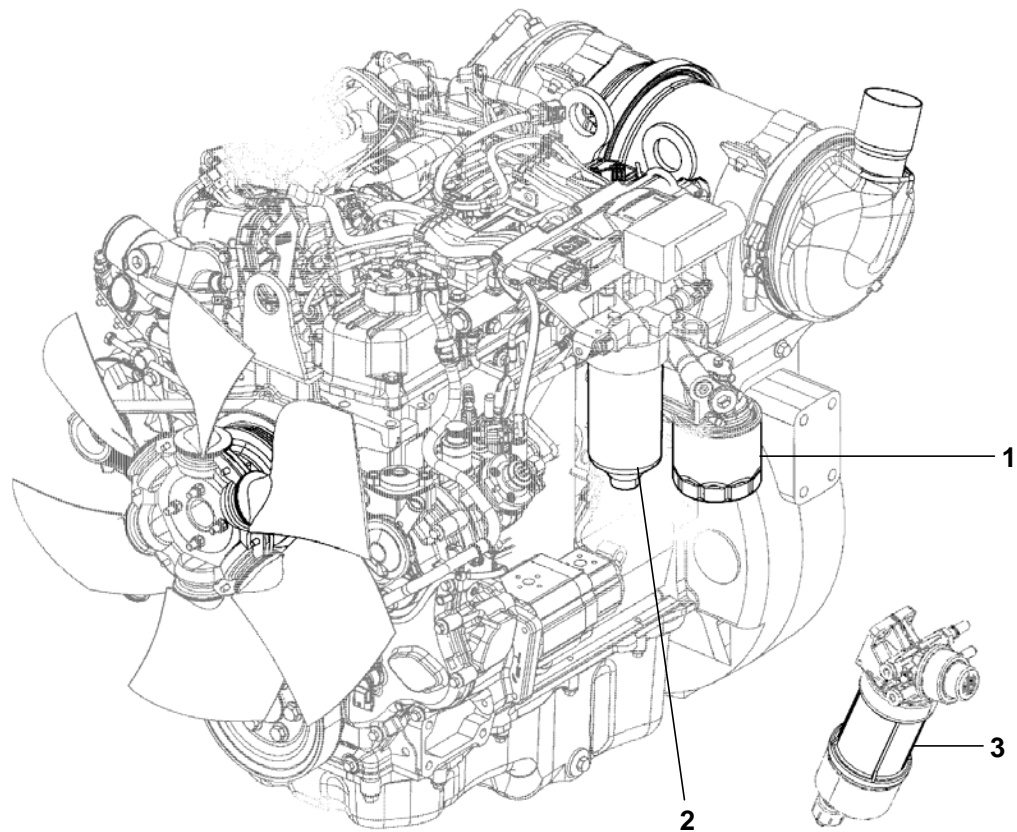

Tav. **Z99 14**
Tab.

Validità da matricola / a matricola: **BF08HB1078** /
PIN Nr. from / to :

COD.ORDINE: **445Z9914XX**
S/P ORDER :